

MESAN
USA

www.mesanusa.com

sales@mesanusa.com



- Specifications & Design are subject to change without notice.
- All rights reserved.

2014-12L/MXL/IP

2015



MXL Series
Cross Flow Induced Draft

MXL Series

Cross Flow, Induced Draft



For over 40 years, the MESAN Group has engaged in the engineering and manufacturing of high quality, high efficiency evaporative cooling equipment. Through hard work, ethics, and a constant pursuit of excellence, MESAN has become a leader in the cooling tower industry in Asia. Today, MESAN continues to play a vital role in the development of new technologies and products, and is proud to have been selected as a key supplier for many renowned projects in the global market.



MESAN is an ISO-9001 and 14001 certified company; our towers were the first ones in Hong Kong and China to obtain the CTI STD-201 performance certification, all of our products are ASHRAE-90.1-2013 compliant, a requisite towards LEED certification for Green Buildings by the USGBC (United States Green Building Council). All this confirms MESAN's constant pursuit of excellence and world-class quality.



MESAN's focus on engineering, research and development, quality management and excellent customer service, is the powerful combination that drives the MESAN brand up on a constant and steady growth. The many patents granted, are proof of MESAN's strive for delivering new environmentally friendly technologies and energy efficient products for the global markets.



MESAN USA strategically located at the center of the Americas continent, in Miami, Florida, USA, consolidates MESAN Group's global presence and reiterates its commitment to provide world-class products for an ever-expanding market.

MESAN USA offers local presence, local inventory of equipment and spare parts and bilingual technical support as well as customer service, in English and Spanish. All products offered by MESAN USA have been engineered to

meet and exceed all codes and standards applicable in this hemisphere.

Overview

The new redesigned MXL series is the most versatile one in our product line up. It now includes many different configurations to fit multiple and varied applications like low profile units, containerized towers, modular units, energy saving models, space saving towers, which gives the customer the opportunity to choose the tower that better adapts to their particular project, and all with the high quality and reliability of all MESAN products.

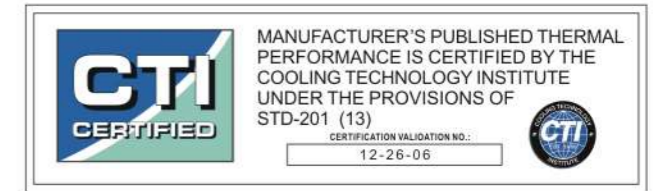

The MXL series is available in 19 boxes with 139 models with capacities ranging from 142 tons to 1,107 tons.

Model Designation

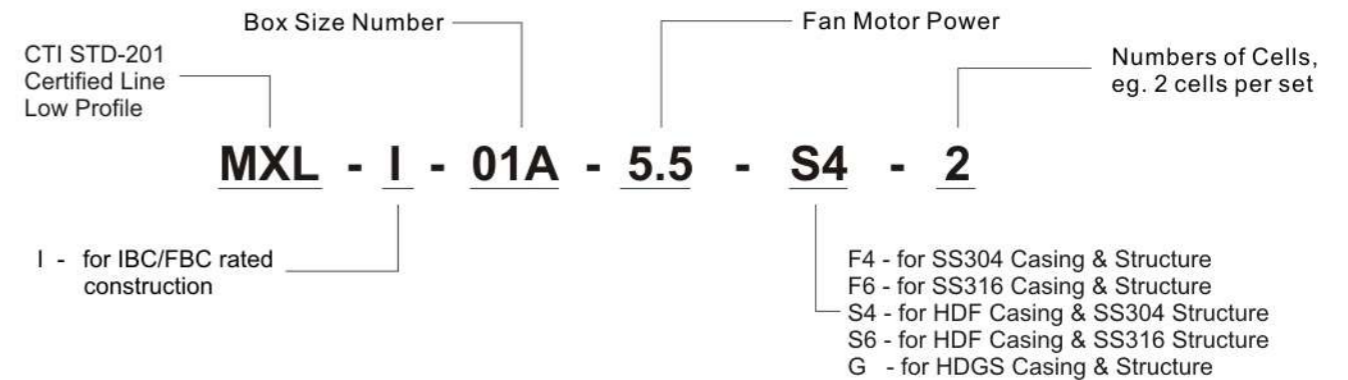

Advantages

- Application versatility, there always is a configuration to meet any application
- Flexibility, the MXL series easily adapts to the changing demands of the different global markets
- Code compliance, the MXL series meets and exceeds many standards and codes like ASHRAE-90.1 2013 (in some models), IBC (International Building Code), FBC (Florida Building Code) (for MXL-I models), etc
- Performance guarantee, all models in the MXL series are CTI-certified as per STD-201
- Reliability, industrial-grade construction and unique design features, not only differentiates us from our competitors but ensures the longest service life
- Broadest materials offering, the MXL series can be manufactured in our proprietary HDF (High Density Fiberglass), HDGS (Hot-Dipped Galvanized Steel, or SS-304 and SS-316 (two grades of stainless steel). We can also combine any of these materials.



Trust MESAN with your evaporative cooling needs.



Tower Structure

- 01 Fan Guard
- 02 Fan
- 03 Fan stack
- 04 Framework
- 05 Basin
- 06 Casing
- 07 Motor
- 08 Motor Support
- 09 Infill
- 10 Hot Water Basin
- 11 V-Belt Reducer
- 12 Water Inlet
- 13 Internal Walkway
- 14 Access Door
- 15 Cold Water Basin

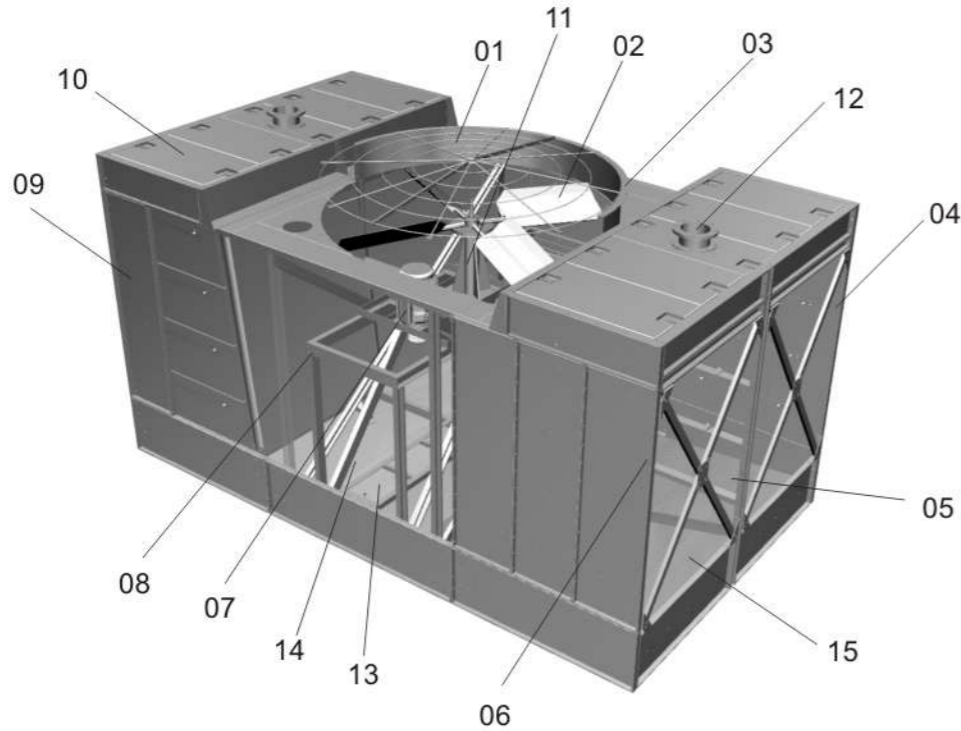

Factory Assembled

Model 01, up to water flow 803 gpm can be containerized. Units 13 feet and higher can be pre-assembled in two halves (upper and lower) and shipped as factory pre-assembled on trailers. For contractors, to be able to take delivery of fully assembled units means reduced installation labor and costs with unsurpassed turn around times. It also ensures the best quality and sealing between wet surfaces.

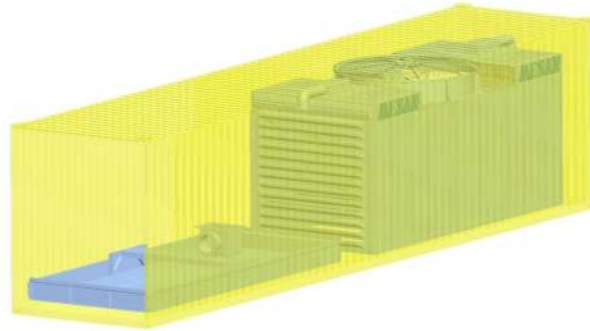

Mechanical Components

Motor

TEAO type, IP55 enclosure, class F insulation, high efficiency, and specially designed to operate within the high-humidity environment of a cooling tower.

Fan

High efficiency, axial, aluminum alloy fans, with innovative low drag, aerodynamic airfoil blade design, adjustable pitch blades and low-noise.



Speed Reducer

Fans are driven by low-speed V-belt reducers. Our reducers have very sturdy design with large diameter high tensile strength steel shafts; NSK permanently lubricated sealed bearings, isolated from the airstream within a sealed enclosure. Our V-belts designed to withstand the rigors of the humid environment, and ensure long and reliable operation.

Casing and Structure

The MXL series is available in several construction materials:

HDF(High Density FRP), which is a special manufacturing process that produces very smooth surfaces on both sides of the components and higher structural strength. HDF allows for self-supporting fiberglass casings with almost no steel structure. Smooth inner surfaces on wet parts reduces bacteria growth and facilitates maintenance. This material provides the ultimate corrosion resistance.



HDGS (Hot Dipped Galvanized Steel), this is a cost effective alternative to casing construction, with good structural strength and adequate corrosion resistance. G235 quality is the highest galvanized grade in the market.

SS-304 or SS-316 stainless steel construction are also available for the highest corrosion resistance

Water Distribution System

Hot Water Basins

Gravity water flow distribution, without nozzles, plus high efficiency diffuser baffles, ensure uniform coverage of the infill surface.

Infill

High efficiency infill, maximizes the contact surface between water and air, allowing for higher evaporation rates and improved heat transfer, while offering the lowest resistance to air flow, for reduced air pressure drop and lowest energy consumption. Staggered infill sheets, are designed for easier replacement in smaller sections, as opposed to other brands' design in very large full height sheets that are very costly to replace. If a small section of MESAN's infill gets accidentally damaged, there is no need to replace the whole sheets, just the small damaged section.

Another feature of MESAN's infill is the built-in primary drift eliminators, that when coupled with the optional secondary drift eliminators provides the lowest possible drift losses.





Product Technical Data

Model MXL	Nominal Tons	HP	Tower Dimensions			Remark	
			L	W	H		
01A	3	142	5	7'- 5 1/4"	17'- 3 1/2"	9'- 7 3/4"	CNT
	4	156	5				
	5.5	172	7 1/2				
	7.5	191	10				
	11	216	15				
01B	3	173	5	7'- 5 1/4"	17'- 3 1/2"	11'- 10 1/2"	
	4	192	5				
	5.5	213	7 1/2				
	7.5	236	10				
	11	267	15				
02A	4	191	5	8'- 6"	19'- 3 1/2"	9'- 7 3/4"	
	5.5	211	7 1/2				
	7.5	235	10				
	11	266	15				
	15	295	20				
	18.5	316	25				
	22	335	30				
02B	4	222	5	8'- 6"	19'- 3 1/2"	11'- 3 1/2"	TRL
	5.5	247	7 1/2				
	7.5	272	10				
	11	308	15				
	15	342	20				
	18.5	365	25				
02C	4	251	5	8'- 6"	19'- 3 1/2"	13'- 1/4"	
	5.5	279	7 1/2				
	7.5	308	10				
	11	349	15				
	15	387	20				
	18.5	414	25				
	22	439	30				
03A	4	210	5	9'- 9 3/4"	20'- 3/4"	10'- 1 3/4"	TRL
	5.5	233	7 1/2				
	7.5	257	10				
	11	292	15				
	15	323	20				
03B	4	247	5	9'- 9 3/4"	20'- 3/4"	11'- 9 1/4"	
	5.5	273	7 1/2				
	7.5	302	10				
	11	343	15				
	15	380	20				
03C	4	285	5	9'- 9 3/4"	20'- 3/4"	13'- 6 1/4"	
	5.5	316	7 1/2				
	7.5	349	10				
	11	396	15				
	15	439	20				
	18.5	468	25				
	22	496	30				
30	549	40					

Notes:
 1)Nominal tons flow is for 3gpm of water cooled from 95°F to 85 °F with 78 °F entering wet-bulb temperature.
 2)Satisfactory performance is based on precise selection, proper system design and installation in a clean and well-ventilatd location.
 3)Models with overall height of 13 feet or more, if required as factory-assembled units, will ship in two halves or bottom/top sections.
 4)CNT: Containerized, TRL: Trailer.

Product Technical Data

Model MXL	Nominal Tons	HP	Tower Dimensions			Remark	
			L	W	H		
04A	7.5	295	10	11'- 9 3/4"	22'- 7 1/4"	10'- 5 1/2"	TRL
	11	336	15				
	15	371	20				
	18.5	398	25				
	22	420	30				
04B	7.5	351	10	11'- 9 3/4"	22'- 7 1/4"	12'- 1 1/4"	
	11	398	15				
	15	440	20				
	18.5	471	25				
	22	499	30				
	30	552	40				
	45	631	60				
04C	7.5	399	10	11'- 9 3/4"	22'- 7 1/4"	13'- 10 1/4"	
	11	452	15				
	15	501	20				
	18.5	536	25				
	22	567	30				
	30	627	40				
	45	716	60				
04D	7.5	442	10	11'- 9 3/4"	22'- 7 1/4"	15'- 5 3/4"	TRL
	11	501	15				
	15	555	20				
	18.5	594	25				
	22	628	30				
04E	7.5	484	10	11'- 9 3/4"	22'- 7 1/4"	17'- 1"	
	11	549	15				
	15	608	20				
	18.5	652	25				
	22	690	30				
04F	7.5	520	10	11'- 9 3/4"	22'- 7 1/4"	18'- 8 3/4"	
	11	590	15				
	15	653	20				
	18.5	700	25				
	22	741	30				
	30	820	40				
	45	939	60				

Notes:
 1)Nominal tons flow is for 3gpm of water cooled from 95°F to 85 °F with 78 °F entering wet-bulb temperature.
 2)Satisfactory performance is based on precise selection, proper system design and installation in a clean and well-ventilatd location.
 3)Models with overall height of 13 feet or more, if required as factory-assembled units, will ship in two halves or bottom/top sections.
 4)CNT: Containerized, TRL: Trailer.



Product Technical Data

Model	Nominal Tons	HP	Tower Dimensions			Remark				
			L	W	H					
05A	11	436	15	13'- 11 3/4"	23'- 10 1/4"	12'- 1 1/4"				
	15	483	20							
	18.5	517	25							
	22	547	30							
	30	606	40							
	37	650	50							
05B	45	693	60	13'- 11 3/4"	23'- 10 1/4"	13'- 10 1/4"				
	11	498	15							
	15	550	20							
	18.5	590	25							
	22	624	30							
	30	691	40							
	37	741	50							
	45	791	60							
05C	55	845	75	13'- 11 3/4"	23'- 10 1/4"	15'- 5 3/4"				
	11	553	15							
	15	612	20							
	18.5	656	25							
	22	694	30							
	30	768	40							
	37	822	50							
	45	876	60							
05D	55	938	75	13'- 11 3/4"	23'- 10 1/4"	17'- 1"				
	11	605	15							
	15	669	20							
	18.5	718	25							
	22	760	30							
	30	843	40							
	37	903	50							
	45	963	60							
	55	1,029	75							
	05E	11	652				15	13'- 11 3/4"	23'- 10 1/4"	18'- 8 3/4"
		15	721				20			
		18.5	772				25			
22		818	30							
30		906	40							
37		970	50							
45	1,036	60								
55	1,107	75								

Foundation and Piping

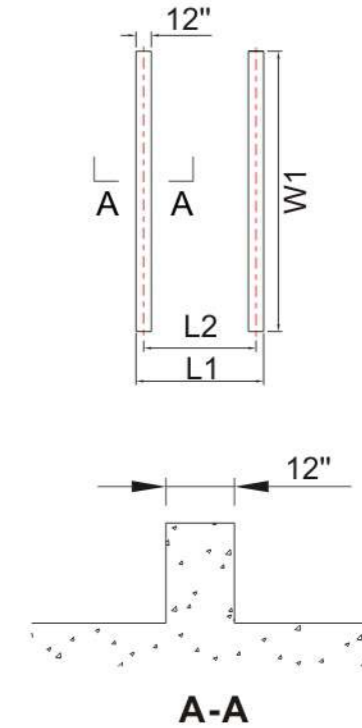
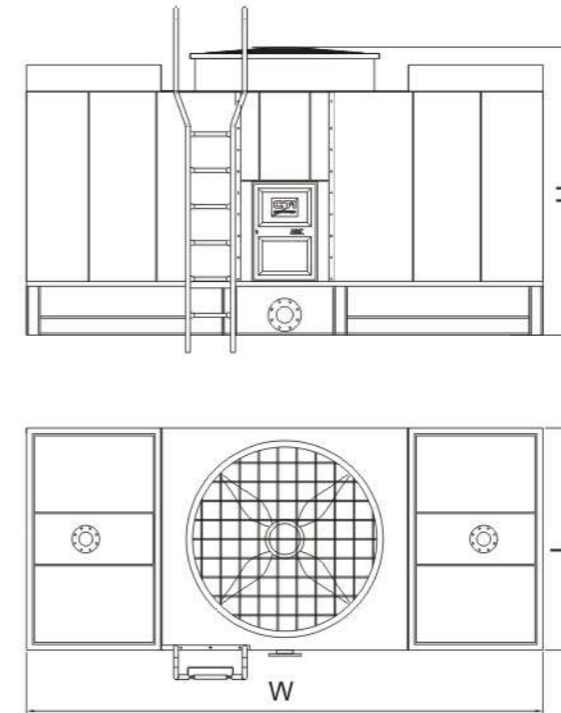

Model	Foundation Dimensions			Pipe Connections					
	MXL	L1	L2	W1	Inlet	Outlet	Overflow	Drain	M-U
01A		8'- 2 1/2"	7'- 3"	18'- 1/2"	6"×2	6"	2"	1 1/2"	1"
01B		8'- 2 1/2"	7'- 3"	18'- 1/2"	6"×2	8"	3"	1 1/2"	1"
02		9'- 3 1/4"	8'- 3 1/2"	20'- 4"	6"×2	8"	3"	1 1/2"	1"
03		10'- 7"	9'- 7"	21'	8"×2	10"	3"	2"	1 1/2"
04A~04D		12'- 7"	11'- 7"	23'- 7 1/2"	6"×4	10"	3"	2"	1 1/2"
04E~04F		12'- 7"	11'- 7"	23'- 7 1/2"	6"×4	12"	4"	4"	2"
05A~05C		14'- 9 1/4"	13'- 9 1/2"	24'- 11 1/4"	6"×4	12"	4"	4"	2"
05D~05E		14'- 9 1/4"	13'- 9 1/2"	24'- 11 1/4"	8"×4	14"	4"	4"	2"

Notes:

- Nominal tons flow is for 3gpm of water cooled from 95°F to 85 °F with 78 °F entering wet-bulb temperature.
- Satisfactory performance is based on precise selection, proper system design and installation in a clean and well-ventilated location.
- Models with overall height of 13 feet or more, if required as factory-assembled units, will ship in two halves or bottom/top sections.
- CNT: Containerized, TRL: Trailer, CKD: Knocked-down model.

Notes:

Secure the base of the cooling tower with the anchor bolts. Buyer is responsible for the tower support and for the positioning and diameter of the anchoring bolts to comply with local building codes.



Optional Accessories

HDGS Construction

For those jobs requiring non-combustible tower casings, we offer a low cost hot-dipped galvanized option, using G235 steel, the highest grade available.

To meet Florida Building Code's high-wind load ratings, we offer a special construction option called MXL-I rated for 150 psf. Only in metal construction though

Stainless-steel Construction

When the ultimate corrosion resistance and non combustibility is required, we offer either SS304 or SS316 construction; also any combination of the two is available.

Motors

Single-speed, TEAO enclosure, but as optional we can also supply NEMA-Premium, VFD-compatible or 2-speed motors.

Super Low Noise Fan

Standard fans are low-noise aluminum airfoil blades, but also available are the "Silent-Choice" super low-noise type with over 15dBA reduction in noise levels.

Gear Reducers

Our standard is belt-driven speed reducers, but as an option we also offer 90° and 180° gear reducers.

Discharge Sound Attenuators

Designed for low air pressure drop, our discharge sound attenuators offer a cost-conscious way to mitigate noise from the tower fan.

Other Optional Accessories

Motor	High Efficiency Motor	Others	Basin Heater
	Two Speed Motor		Discharge Sound Attenuator
	VFD Motor		OSHA Fan Guard
Fan	FRP Fan		OSHA-compliant Ladder Safety Cage and Handrail
	Low Noise Fan		Removable Strainer
Reducer	180° Gear Box		Service Platform to Fully Cover the Cold Water Basin
	90° Gear Box		SS/HDGS Louver
Infill	ASTM PVC Infill		Variable and Constant Speed Control Panels
	High Temperature PP Infill		Vibration Cut-off Switch



MESAN guarantees the thermal performance of its CTI certified products. All CTI models are fully compliant with ASHRAE 90.1. Cooling Technology Institute (CTI) is dedicated to promoting truthful rating of cooling tower capacity, provides a third party independent verification and periodic monitoring of the products thermal efficiency. Having CTI certified products eliminates the need for costly onsite field test and ensures the system performance will meet the design objectives, for the benefit of the building owners, operators and public.

MXR-KM



MXL



MXC



MCC

