

Honeywell

VR2, VR3, VR4, VR5 Resilient Seat Butterfly Valves with Lugged Connections

SPECIFICATION DATA



Two-Way Valves (VR2)

- Sizes from 2 to 24 inches with ANSI Class 125/150 lug pipe connections
- Modified equal percentage flow characteristic
- Spring fail safe available on 2 and 2.5 inch models, Electronic fail safe available on 3 to 12 inch models
- NEMA 2 and NEMA 4X actuators available on valves 5 inch and smaller, NEMA 4X actuators available on valves 5 inch to 24 inch

Three-Way Valve Assemblies (VR3,4,5)

- Sizes from 2 to 18 inches with ANSI Class 125/150 lug pipe connections
- Mixing or diverting control
- Modified linear flow characteristic
- Standard cast-iron pipe T included
- Multiple port configurations available to fit different applications
- Spring fail safe available on 2 inch models, Electronic fail safe available on 2.5 to 12 inch models
- NEMA 2 and NEMA 4X actuators available on valves 3 inch and smaller, NEMA 4X available on valves 3 inch to 18 inch

FEATURES

All Models

- Bi-directional flow
- 304 stainless steel disks
- Ductile iron valve body for increased strength and durability
- Stainless steel valve stem
- EPDM resilient valve seat doubles as flange gasket
- Bubble-tight seat leakage at rated close-off
- Close-off rating of 200 psid in sizes 2 in. to 12 in.
- Close-off rating of 150 psid in sizes 14 in. to 24 in.
- ISO 5211 actuator mounting flange
- Available with factory-installed electric actuation interfaces in 2-position, Floating (“tri-state”), or Modulating (2-10 Vdc) Control
- Manual override on all models
- Fail-safe actuators available on valves up to 12 inches
- For use with hot, chilled or condensing water with up to 60% glycol in HVAC systems

Contents

FEATURES	1
SPECIFICATIONS	2
DIMENSIONAL DRAWINGS	5
ACTUATOR SPECIFICATIONS	13
3-WAY VALVE PATTERNS	15



31-00283EF-01

SPECIFICATIONS

NOTE: All specifications were accurate at time of publication. Honeywell reserves the right to improve or discontinue products without prior notification. To obtain the latest technical literature, please consult the website at <http://customer.honeywell.com>.

Models:

See Table 1

Dimensions:

See Fig. 1–20

Mounting:

for ASME/ANSI class 125/150 flanges

Body Style:

Two-way or Three-way lugged butterfly valve

Body Size:

2-way: 2 in. to 24 in.

3-way: 2 in. to 18 in.

Flow Characteristics:

2-way: modified equal percentage

3-way: modified linear

Body Static Pressure Rating (maximum):

Consistent with ASME/ANSI Class 125

Cold Working Pressure:

232 psi

Close-Off Pressure Rating (maximum differential):

2 in. to 12 in. valves: 200 psi

14 in. to 24 in. valves: 150 psi

Controlled Media:

Chilled or hot water up to 60% glycol

Media Temperature range:

-22 °F to 250 °F (-30 °C to 121 °C)

Maximum velocity:

12 fps (3.7 m/s)

Materials:

Body:

2 in. to 6 in. and 14 in. to 24 in.: epoxy powder coated ductile iron ASTM A536.

8 in. to 12 in.: polyester powder coated ductile iron ASTM A536

Disk: 304 stainless steel

Shaft:

2 in. to 6 in. and 14 in. to 24 in.: 416 stainless steel

8 in. to 12 in.: 420 stainless steel

Seat: EPDM

O-rings: EPDM

Bushings:

2 in. to 6 in. and 14 in. to 24 in.: RPTFE

8 in. to 12 in.: bronze, steel, PTFE

Approvals/Standards:

Close-off: Bubble-tight design up to rated close-off pressure.

Actuators on valves 12 inch and smaller: cULus, CE

Actuators on valves 14 inch and larger: cCSAus, CE

Actuator Ambient Temperature Ratings:

See Table

Accessories:

MB-IND-1

Position Indicator Small

MB-IND-2

Position Indicator Large

MB-NSR-SWITCH

NSR DCA Aux Switch

MB-NSR-N4HEAT

NSR NEMA4 DCA Heater Kit

(Must be ordered with valve, factory installed)

MB-SR-N4HEAT

SR NEMA4 DCA Heater Kit

(Must be ordered with valve, factory installed)

Table 1. Butterfly valve assembly model selection

Butterfly Valve	Connection Type	Body Pattern	Valve Size	Actuator Control Signal	Actuator Voltage	Fail Safe Function	Voltage / Switch Feedback	Nema Rating	Description	
V	Valve, Lugged (butterfly)									
	R	Resilient Seat ANSI 125/150 (Standard)								
		2	2-way							
		3	3-way configurations (see Fig. 20)							
		4								
		5								
		5								
		F	2 inch (DN 50)							
		G	2.5 inch (DN 65)							
		H	3 inch (DN 80)							
		J	4 inch (DN 100)							
		K	5 inch (DN 125)							
		L	6 inch (DN 150)							
		M	8 inch (DN 200)							
		N	10 inch (DN 250)							
		P	12 inch (DN 300)							
		R	14 inch (DN 350)							
	S	16 inch (DN 400)								
	T	18 inch (DN 450)								
	U	20 inch (DN 500) 2-way only								
	V	24 inch (DN 600) 2-way only								
		6	Floating / Two-Position (SPDT)							
		7	Analog Modulating (0)2-10 Vdc							
		8	Two-Position (SPST)							
		L	24 Vac/Vdc							
		H	120 Vac							
		U	24-240 Vac / 24-125 Vdc							
		P	Fail in place							
		S	Spring Return A-port (Master) fail safe open							
		T	Spring Return A-port (Master) fail safe closed							
		E	Electronic Fail Safe (default fail closed, field adjustable)							
		N	No Feedback							
	F	Analog Feedback								
	S	Built in Aux Switches								
	B	Both Analog Feedback and Aux Switches								
	2	NEMA 2								
	4	NEMA 4X								
	H	NEMA 4X (with Heater)								
V	R	2	H	7	L	P	F	2	Example: 2-WAY, 3 INCH, RESILIENT SEAT BUTTERFLY VALVE, CV302, CLOSE-OFF 200PSI, 24VAC, 2-10VDC, 150S, FAIL-SAFE IN PLACE, FEEDBACK, NEMA2, (INCLUDES MBP7L4F2/U ACTUATOR)	

Table 2. Butterfly valve replacement actuator model selection

Type	Fail safe	Control	Power	Actuator type	Feedback	Nema	Description
MB	Motor Butterfly						
	S	Spring fail-safe					
	E	Electronic fail-safe					
	P	Fail-in-place					
	6	Floating / Two-Position (SPST)					
	7	Analog Modulating (0)2-10 VDC					
	8	Two-Position (SPST)					
	L	24 Vac/Vdc					
	H	120 Vac					
	U	24-240 Vac / 24-125 Vdc					
	1	SR 180 in-lb					
	2	NSR 180 in-lb					
	3	SR 180 in-lb					
	A	NSR 180 in-lb					
	4	EFS/FIP 360 in-lb (2-way VR)					
	R	EFS/FIP 360 in-lb (VH and 3-way VR)					
	5	EFS/FIP 800 in-lb					
	6	EFS/FIP 1400 in-lb (3, 4, 5, 6, 12 inch valves)					
	7	EFS/FIP 1400 in-lb (8 inch valves)					
	8	EFS/FIP 1400 in-lb (10 inch valves)					
	9	FIP 3540 in-lb					
	B	FIP 4425 in-lb					
	C	FIP 5755 in-lb					
	D	FIP 8850 in-lb					
	E	FIP 13275 in-lb					
	F	FIP 17700 in-lb					
	G	FIP 22125 in-lb					
H	FIP 26550 in-lb						
N	No feedback						
F	Analog feedback						
S	Built in Aux Switches						
B	Both Analog Feedback and Aux Switches						
2	NEMA 2						
4	NEMA 4X						
H	NEMA 4X (with HEATER)						
MB	S	8	U	1	N	2	Example: BUTTERFLY VALVE ACTUATOR FOR VR AND VH SERIES, SPRING RETURN, 2-POSITION, 24-240VAC, 180 LB-IN, NEMA2

NOTE: The tables above are intended to explain the significance of the butterfly valve and actuator part numbering system, and is not a product configuration tool. Only part numbers printed in Honeywell price books may be ordered. Please refer to cpq.honeywell.com for available configurations.

DIMENSIONAL DRAWINGS

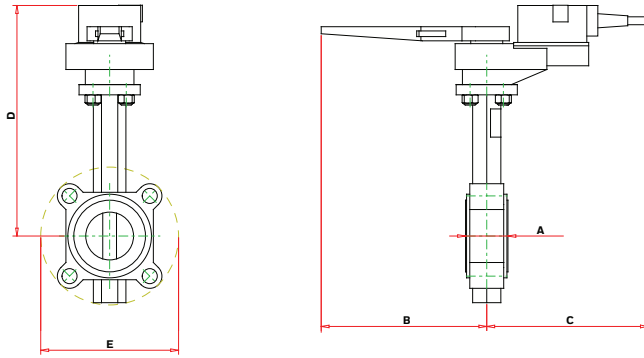

Size		Dimensions, in. (mm)				
in.	DN	A	B	C	D	E
2	50	1.77 (45)	6.93 (176)	6.77 (172)	9.65 (245)	5.77 (147)
2.5	65	1.90 (48)	6.93 (176)	6.77 (172)	10.20 (259)	6.52 (166)

Fig. 1. 2-way valves with NEMA 2 MBP... 2,3 actuators

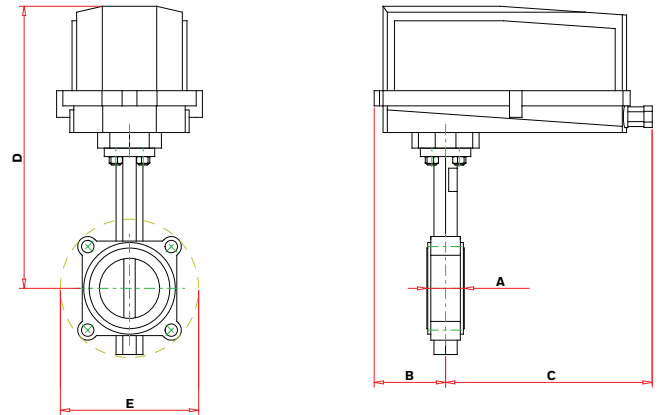

Size		Dimensions, in. (mm)				
in.	DN	A	B	C	D	E
2	50	1.77 (45)	3.62 (92)	10.49 (266)	13.54 (344)	5.77 (147)
2.5	65	1.90 (48)	3.62 (92)	10.49 (266)	14.09 (358)	6.52 (166)
3	80	1.90 (48)	3.62 (92)	10.49 (266)	14.32 (364)	7.02 (178)

Fig. 3. 2-way valves with NEMA 4 MBP,E...3,4 actuators

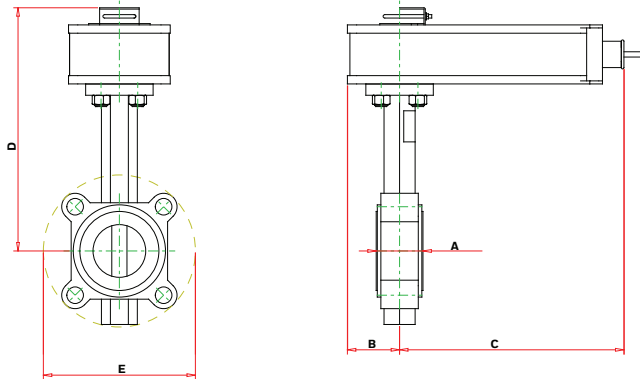

Size		Dimensions, in. (mm)				
in.	DN	A	B	C	D	E
2	50	1.77 (45)	1.98 (50)	8.52 (216)	9.23 (234)	5.77 (147)
2.5	65	1.90 (48)	1.98 (50)	8.52 (216)	9.78 (248)	6.52 (166)

Fig. 2. 2-way valves with NEMA 2 MBS...3 actuators

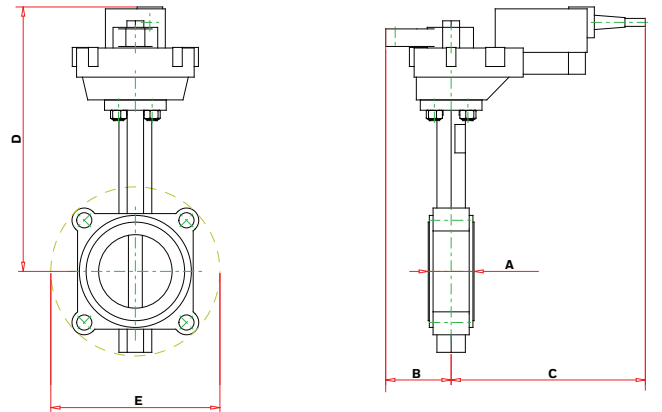

Size		Dimensions, in. (mm)				
in.	DN	A	B	C	D	E
3	80	1.90 (48)	2.72 (69)	8.06 (205)	10.98 (279)	7.02 (178)

Fig. 4. 2-way valves with NEMA 2 MBP...4 actuators

VR2, VR3, VR4, VR5 RESILIENT SEAT BUTTERFLY VALVES WITH LUGGED CONNECTIONS

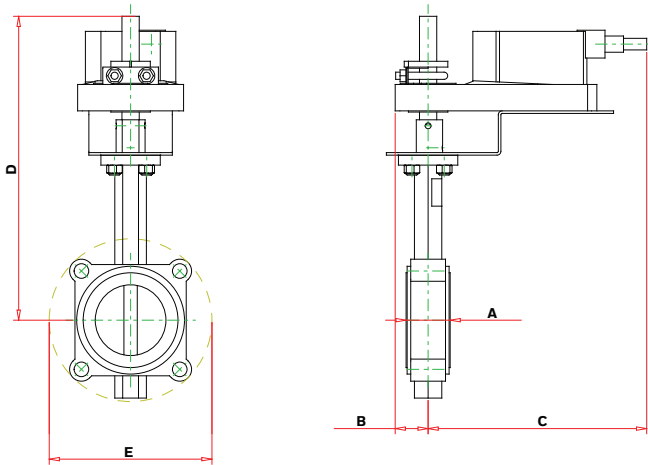

Size		Dimensions, in. (mm)				
in.	DN	A	B	C	D	E
3	80	1.90 (48)	1.42 (36)	9.43 (240)	13.11 (333)	7.02 (178)

Fig. 5. 2-way valves with NEMA 2 MBE...4 actuators

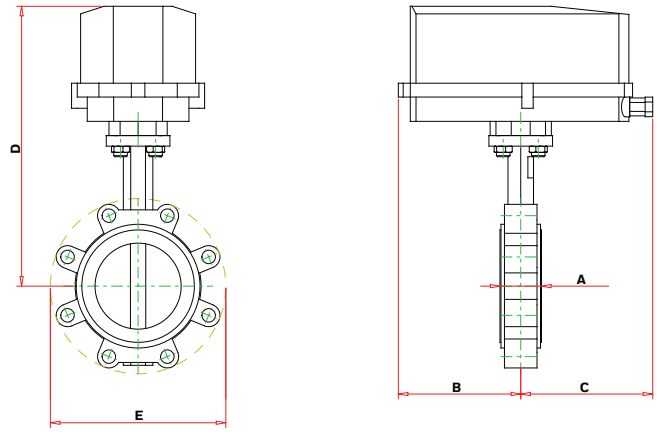

Size		Dimensions, in. (mm)				
in.	DN	A	B	C	D	E
4	100	2.15 (55)	6.81 (173)	7.34 (186)	15.07 (383)	8.52 (216)
5	125	2.31 (59)	6.81 (173)	7.34 (186)	15.59 (396)	9.76 (248)

Fig. 7. 2-way valves with NEMA 4 MBP,E...5 actuators

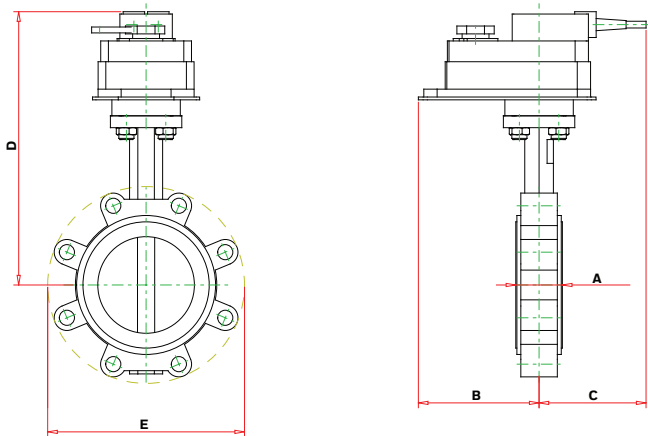

Size		Dimensions, in. (mm)				
in.	DN	A	B	C	D	E
4	100	2.12 (55)	5.99 (152)	5.30 (135)	13.03 (331)	8.52 (216)
5	125	2.31 (59)	5.99 (152)	5.30 (135)	13.55 (344)	9.76 (248)

Fig. 6. 2-way valves with NEMA 2 MBP,E...5 actuators

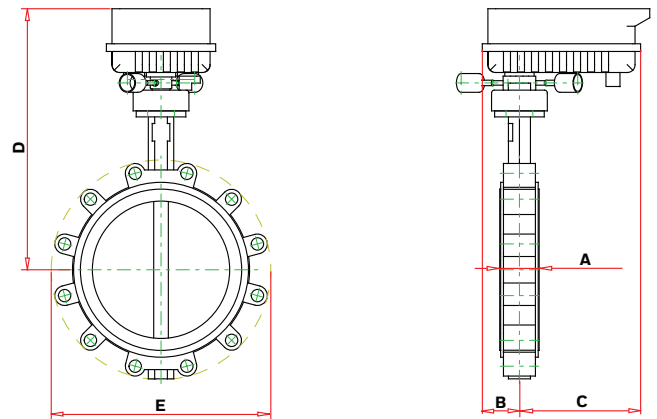

Size		Dimensions, in. (mm)				
in.	DN	A	B	C	D	E
6	150	2.20 (56)	2.65 (67)	9.30 (236)	16.03 (407)	10.76 (273)
8	200	2.36 (60)	2.65 (67)	9.30 (236)	17.37 (441)	13.02 (331)
10	250	2.68 (68)	2.65 (67)	9.30 (236)	18.63 (473)	15.68 (398)
12	300	3.07 (78)	2.65 (67)	9.30 (236)	20.40 (518)	18.40 (467)

Fig. 8. 2-way valves with MBP...6,7,8 actuators

VR2, VR3, VR4, VR5 RESILIENT SEAT BUTTERFLY VALVES WITH LUGGED CONNECTIONS

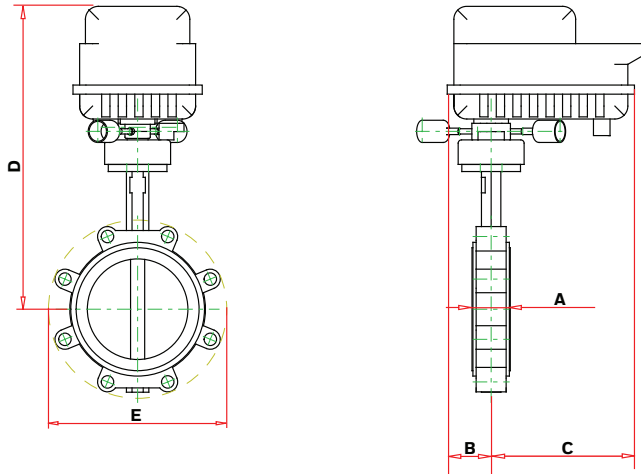

Size		Dimensions, in. (mm)				
in.	DN	A	B	C	D	E
5	125	2.20 (56)	2.65 (67)	9.30 (236)	17.77 (451)	9.76 (248)
6	150	2.20 (56)	2.65 (67)	9.30 (236)	18.28 (464)	10.76 (273)
8	200	2.36 (60)	2.65 (67)	9.30 (236)	19.62 (498)	12.96 (329)
10	250	2.68 (68)	2.65 (67)	9.30 (236)	20.88 (530)	15.66 (398)
12	300	3.07 (78)	2.65 (67)	9.30 (236)	22.65 (575)	18.40 (467)

Fig. 9. 2-way valves with MBE...6,7,8 actuators

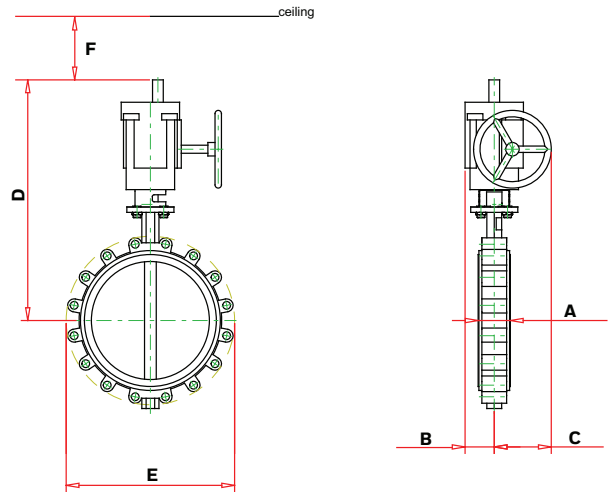

Size		Dimensions, in. (mm)					
in.	DN	A	B	C	D	E	F
14	350	3.22 (82)	4.40 (112)	7.13 (181)	26.97 (685)	20.39 (518)	15.07 (383)
16	400	4.22 (107)	4.40 (112)	7.13 (181)	30.77 (782)	22.89 (581)	16.70 (424)
18	450	4.71 (120)	4.27 (109)	8.35 (212)	35.22 (895)	24.65 (626)	19.87 (505)
20	500	5.25 (133)	4.27 (109)	8.35 (212)	37.50 (953)	26.89 (683)	19.16 (487)
24	600	6.36 (162)	3.18 (81)	14.98 (381)	43.93 (1116)	31.64 (804)	21.66 (550)

Fig. 10. 2-way valves with MBP...B,C,E,H actuators

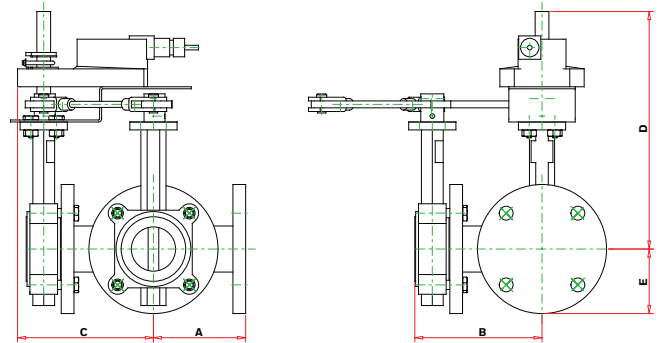

Size		Dimensions, in. (mm)				
in.	DN	A	B	C	D	E
2	50	4.50 (114)	6.27 (159)	6.57 (167)	12.33 (313)	3.00 (76)
2.5	65	5.00 (127)	6.90 (175)	7.37 (187)	12.88 (327)	3.50 (89)

Fig. 11. 3-way valves with NEMA 2 MBP,E...2,3,A,R actuators

VR2, VR3, VR4, VR5 RESILIENT SEAT BUTTERFLY VALVES WITH LUGGED CONNECTIONS

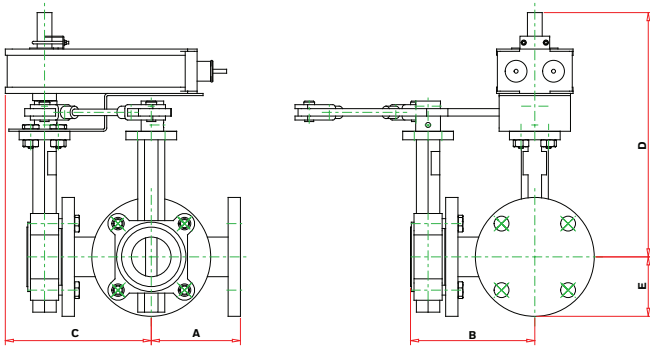

Size		Dimensions, in. (mm)				
in.	DN	A	B	C	D	E
2	50	4.50 (114)	6.27 (159)	7.37 (187)	12.33 (313)	3.00 (76)

Fig. 12. 3-way valves with NEMA 2 MBS...1,3 actuators

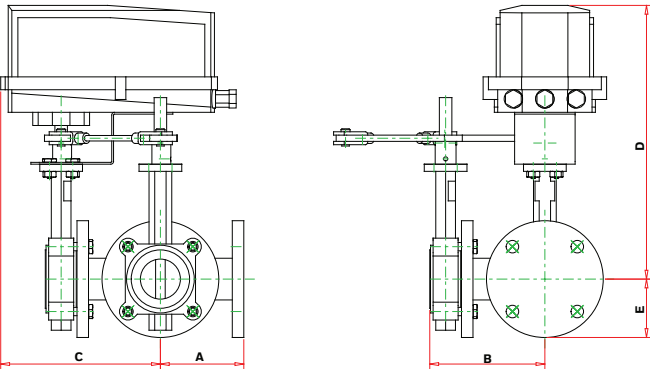

Size		Dimensions, in. (mm)				
in.	DN	A	B	C	D	E
2	50	4.50 (114)	6.27 (159)	9.01 (229)	15.86 (403)	3.00 (76)
2.5	65	5.00 (127)	6.90 (175)	9.57 (243)	16.41 (417)	3.50 (89)

Fig. 13. 3-way valves with NEMA 4 MBP,E...R actuators

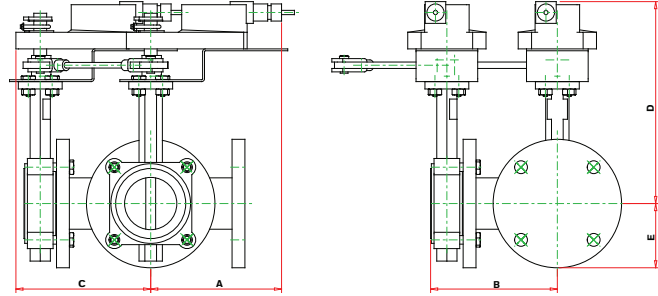

Size		Dimensions, in. (mm)				
in.	DN	A	B	C	D	E
3	80	7.64 (194)	7.40 (188)	7.87 (200)	11.79 (300)	3.75 (95)

Fig. 14. 3-way valves with NEMA 2 MBP...R actuators

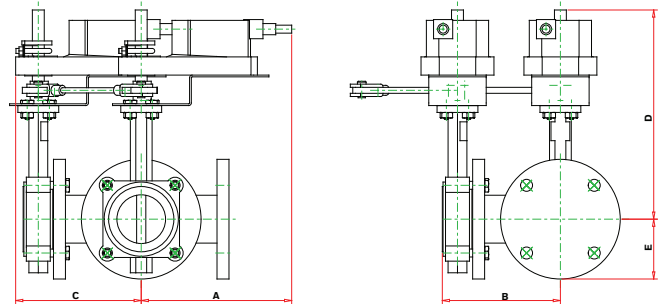

Size		Dimensions, in. (mm)				
in.	DN	A	B	C	D	E
3	80	9.43 (240)	7.40 (188)	7.87 (200)	13.11 (333)	3.75 (95)

Fig. 15. 3-way valves with NEMA 2 MBE...R actuators

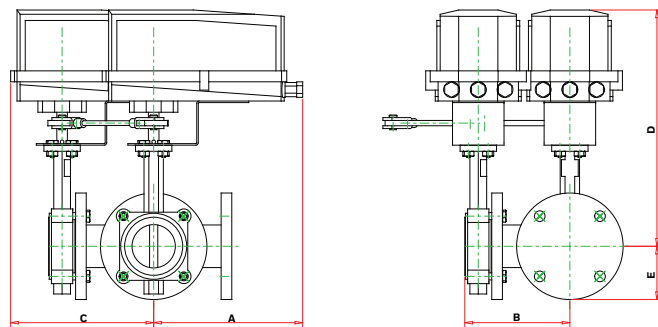

Size		Dimensions, in. (mm)				
in.	DN	A	B	C	D	E
3	80	10.49 (266)	7.40 (188)	10.07 (256)	16.64 (423)	3.75 (95)

Fig. 16. 3-way valves with NEMA 4 MBP...R actuators

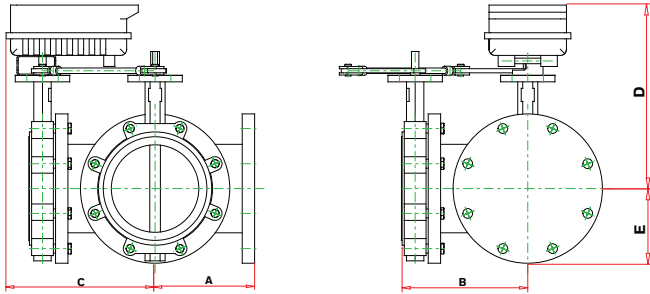

Size		Dimensions, in. (mm)				
in.	DN	A	B	C	D	E
3	80	5.50 (140)	7.56 (192)	8.89 (226)	14.97 (380)	3.75 (95)
4	100	6.50 (165)	8.55 (217)	11.13 (283)	14.22 (361)	4.50 (114)
5	125	7.50 (191)	9.70 (246)	12.05 (306)	14.74 (374)	5.00 (127)
6	150	8.00 (203)	10.20 (256)	12.55 (319)	15.25 (387)	5.50 (140)
8	200	9.00 (229)	11.36 (289)	13.47 (342)	16.59 (421)	6.75 (172)
10	250	11.00 (279)	13.68 (348)	15.31 (389)	17.85 (453)	8.00 (203)
12	300	12.00 (305)	15.07 (383)	16.12 (409)	19.62 (498)	9.50 (241)

Fig. 17. 3-way valves with MBP...6,7,8 actuators

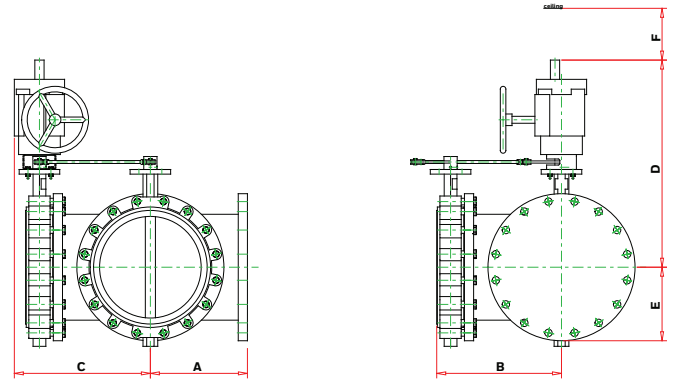

Size		Dimensions, in. (mm)					
in.	DN	A	B	C	D	E	F
14	350	14.00 (356)	17.22 (437)	20.01 (508)	29.51 (750)	10.50 (267)	8.80 (224)
16	400	15.00 (381)	19.22 (488)	21.38 (543)	34.35 (873)	11.75 (299)	8.80 (224)
18	450	16.50 (419)	21.21 (539)	23.13 (588)	35.22 (895)	12.50 (318)	8.80 (224)

Fig. 19. 3-way valves with MBP...C,D,E actuators

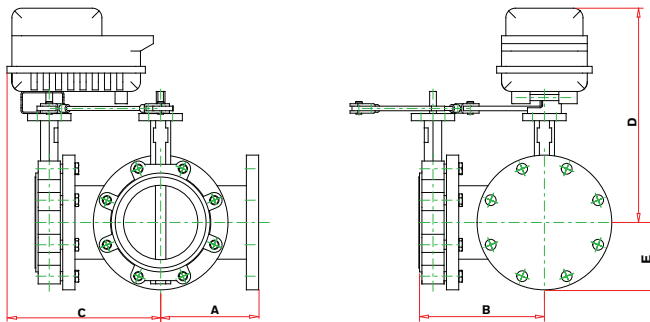

Size		Dimensions, in. (mm)				
in.	DN	A	B	C	D	E
4	100	6.50 (165)	8.55 (217)	11.13 (283)	16.47 (418)	4.50 (114)
5	125	7.50 (191)	9.70 (246)	12.05 (306)	16.99 (432)	5.00 (127)
6	150	8.00 (203)	10.20 (259)	12.55 (319)	17.50 (445)	5.50 (140)
8	200	9.00 (229)	11.36 (289)	13.47 (342)	18.84 (479)	6.75 (172)
10	250	11.00 (279)	13.68 (348)	15.31 (389)	20.10 (511)	8.00 (203)
12	300	12.00 (305)	15.07 (383)	16.12 (409)	21.87 (556)	9.50 (241)

Fig. 18. 3-way valves with MBE...6,7,8 actuators

ACTUATOR SPECIFICATIONS

Table 3. Actuator Specifications.

Actuator Model	Torque	Control Inputs	Fail Safe (Timing)	Supply Voltage	Transformer Sizing	Ambient Temp.	Timing	Enclosure	Aux. Switch			
MBP6L2N2/U	180 in-lb [20 Nm]	2-position; Floating	fail-in-place	24 VAC, ±20%, 50/60 Hz; 24 VDC, ±10%	5.5 VA (class 2)	-22°F to 122°F [-30°C to 50°C]	90s	IP 54 NEMA 2				
MBP6LAN2/U					6 VA (class 2)		150s					
MBP7L2F2/U		Modulating										
MBP7L3F2/U												
MBS8U1N2/U	180 in-lb [20 Nm]	2-position	spring fail-safe (<20s)	24...240 VAC -20% / +10%, 50/60 Hz; 24...125 VDC ±10%	7 VA @ 24 VAC (class 2); 8.5 VA @ 120 VAC; 18 VA @ 240 VAC	-22°F to 122°F [-30°C to 50°C]	<75s	IP 54 NEMA 2	2 x SPDT*			
MBS8U3N2/U								IP 54 NEMA 2				
MBS8U3N4/U								IP 66/67 NEMA 4X				
MBS8U3S2/U								IP 54 NEMA 2				
MBS8U3S4/U								IP 66/67 NEMA 4X				
MBS7L1F2/U	180 in-lb [20 Nm]	Modulating	spring fail-safe (<20s)	24 VAC, ±20%, 50/60 Hz; 24 VDC, -10% / +20%	10 VA (class 2)	-22°F to 122°F [-30°C to 50°C]	150s	IP 54 NEMA 2	2 x SPDT*			
MBS7L3F2/U				24 VAC, ±20%, 50/60 Hz; 24 VDC, ±10%				IP 54 NEMA 2				
MBS7L3F4/U								IP 66/67 NEMA 4X				
MBS7L3B2/U								IP 54 NEMA 2				
MBS7L3B4/U								IP 66/67 NEMA 4X				
MBP6L4N2/U	360 in-lb [40 Nm]	2-position; Floating	fail-in-place	24 VAC, ±20%, 50/60 Hz; 24 VDC, ±10%	6 VA (class 2)	-22°F to 122°F [-30°C to 50°C]	150s	IP 54 NEMA 2				
MBP6LRN2/U					7 VA (class 2)		35s	IP 66/67 NEMA 4X				
MBP6L4N4/U										Modulating	150s	IP 54 NEMA 2
MBP6LRN4/U												
MBP7L4F2/U												
MBP7LRF2/U												
MBP7L4F4/U												
MBP7LRN4/U												
MBE6L4N2/U	360 in-lb [40 Nm]	2-position; Floating	electronic fail-safe (35s)	24 VAC ± 20%, 50/60 Hz; 24 VDC ± 10%	21 VA (class 2)	-22°F to 122°F [-30°C to 50°C]	150s	IP 54 NEMA 2				
MBE6LRN2/U								Modulating		IP 66/67 NEMA 4X		
MBE6L4N4/U											IP 54 NEMA 2	
MBE7L4F2/U		IP 66/67 NEMA 4X										
MBE7LRF2/U												
MBE7L4F4/U												

*3A resistive (0.5A inductive) @ 250 VAC, one set at 10°, one adjustable 10° to 90°
 **3A resistive (0.5A inductive) @ 250 VAC, one set at 10°, one set at 85°

Table 3. Actuator Specifications. (Continued)

Actuator Model	Torque	Control Inputs	Fail Safe (Timing)	Supply Voltage	Transformer Sizing	Ambient Temp.	Timing	Enclosure	Aux. Switch
MBP6L5N2/U	800 in-lb [90 Nm]	2-position; Floating	fail-in-place	24 VAC, ±20%, 50/60 Hz; 24 VDC, ±10%	12 VA (class 2)	-22°F to 122°F [-30°C to 50°C]	35s	NEMA 1	
MBP6L5N4/U								IP 66/67 NEMA 4X	
MBP7L5F2/U		Modulating					150s	NEMA 1	
MBP7L5F4/U								IP 66/76 NEMA 4X	
MBE6L5N2/U	800 in-lb [90 Nm]	2-position; Floating	electronic fail-safe (35s)	24 VAC, ±20%, 50/60 Hz	21 VA (class 2)	-22°F to 122°F [-30°C to 50°C]	150s	NEMA 1	
MBE6L5N4/U								IP 66/67 NEMA 4X	
MBE7L5F2/U		Modulating		NEMA 1				IP 66/67 NEMA 4X	
MBE7L5F4/U									IP 66/67 NEMA 4X
MBP6U6SH/U	1400 in-lb [160 Nm]	2-position; Floating	fail-in-place	24...240 VAC, -20% / +10%, 50/60 Hz; 24...125 VDC, -20% / +10%	20 VA @ 24 VAC/DC (class 2); 23 VA @ 120 VAC/DC; 52 VA @ 230 VAC	-22°F to 122°F [-30°C to 50°C]	35s	IP 66/67 NEMA 4X w/Heater	2 x SPDT*
MBP6U7SH/U									
MBP6U8SH/U									
MBP7U6BH/U									
MBP7U7BH/U									
MBP7U8BH/U									
MBE6U6SH/U	1400 in-lb [160 Nm]	2-position; Floating	electronic fail-safe (30s)	24...240 VAC, -20% / +10%, 50/60 Hz; 24...125 VDC, -20% / +10%	55 VA @ 24 VAC/DC (class 2); 43 VA @ 120 VAC/DC; 68 VA @ 230 VAC	-22°F to 122°F [-30°C to 50°C]	35s	IP 66/67 NEMA 4X w/Heater	2 x SPDT*
MBE6U7SH/U									
MBE6U8SH/U									
MBE7U6BH/U									
MBE7U7BH/U									
MBE7U8BH/U									
MBP6LBH/U	4425 in-lb [500 Nm]	2-position	fail-in-place	24 VAC, ±10%, 50/60 Hz; 24 VDC, ±10%	214 VA	-22°F to 150°F [-30°C to 65°C]	26s	IP 66/67 NEMA 4X w/Heater	2 x SPDT**
MBP7LBBH/U		Modulating							
MBP6HCSH/U	5755 in-lb [650 Nm]	2-position	fail-in-place	120 VAC, ±10%, 50/60 Hz	288 VA	-22°F to 150°F [-30°C to 65°C]	34s	IP 66/67 NEMA 4X w/Heater	2 x SPDT**
MBP7HCBH/U		Modulating			240 VA		38s		
MBP6HDSH/U	2-position	504 VA			50s				
MBP7HDBH/U		Modulating			240 VA		59s		
MBP6HESH/U	2-position	504 VA			51s				
MBP7HEBH/U		Modulating			336 VA		79s		
MBP6HHSH/U	2-position	432 VA			62s				
MBP7HHBH/U		Modulating			516 VA		71s		

*3A resistive (0.5A inductive) @ 250 VAC, one set at 10°, one adjustable 10° to 90°

**3A resistive (0.5A inductive) @ 250 VAC, one set at 10°, one set at 85°

Table 4. Duty Cycle on High Torque Actuators

Actuator Model	Torque	Control Inputs	Duty Cycle
MBP6LBSH/U	4425 in-lb [500 Nm]	2-position	75%
MBP7LBBH/U		Modulating	
MBP6HCSH/U	5755 in-lb [650 Nm]	2-position	30%
MBP7HCBH/U		Modulating	75%
MBP6HDSH/U	8850 in-lb [1000 Nm]	2-position	30%
MBP7HDBH/U		Modulating	75%
MBP6HESH/U	13275 in-lb [1500 Nm]	2-position	30%
MBP7HEBH/U		Modulating	75%
MBP6HSH/U	26550 in-lb [3000 Nm]	2-position	30%
MBP7HHBH/U		Modulating	50%

3-way Valve Configurations

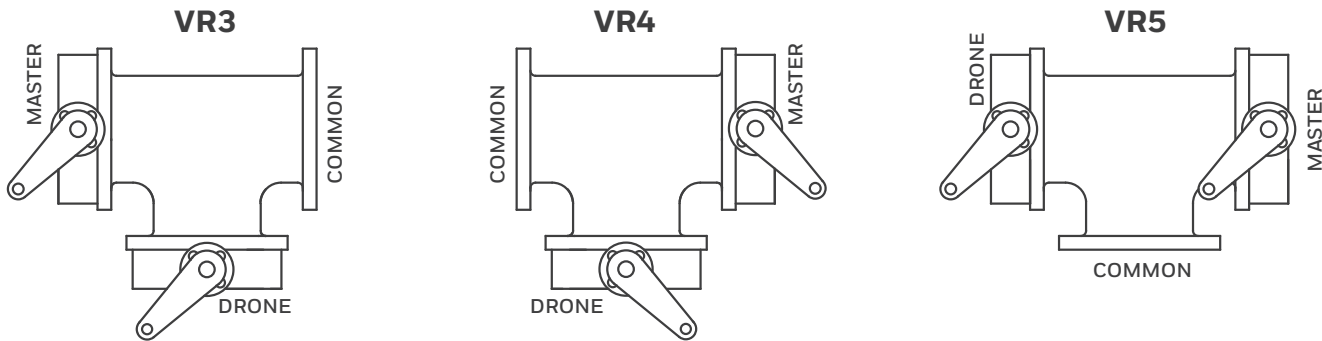

Fig. 20. 3-way valve configurations

Flow Data

Table 5. Valve Cv

Valve Size		Cv								
in.	DN	10°	20°	30°	40°	50°	60°	70°	80°	90°
2	50	0.06	3	7	15	27	44	70	105	115
2.5	65	0.1	6	12	25	45	75	119	178	196
3	80	0.2	9	18	39	70	116	183	275	302
4	100	0.3	17	36	78	139	230	364	546	600
5	125	0.5	29	61	133	237	392	620	930	1022
6	150	0.8	45	95	205	366	605	958	1437	1579
8	200	2	89	188	408	727	1202	1903	2854	3136
10	250	3	151	320	694	1237	2047	3240	4859	5340
12	300	4	234	495	1072	1911	3162	5005	7507	8250
14	350	6	338	715	1549	2761	4568	7230	10844	11917
16	400	8	464	983	2130	3797	6282	9942	14913	16388
18	450	11	615	1302	2822	5028	8320	13168	19752	21705
20	500	14	791	1674	3628	6465	10698	16931	25396	27908
24	600	22	1222	2587	5605	9989	16528	26157	39236	43116

Table 6. Flow Rate

Valve Size		Flow Rate in GPM					
in.	DN	2 FPS	4 FPS	6 FPS	8 FPS	10 FPS	12 FPS
2	50	19	39	59	78	98	117
2.5	65	30	61	92	122	153	184
3	80	44	88	132	176	220	264
4	100	78	157	235	313	392	470
5	125	122	245	367	490	612	734
6	150	176	352	529	705	881	1058
8	200	313	627	940	1253	1567	1880
10	250	490	979	1469	1958	2448	2738
12	300	705	1410	2115	2820	3525	4230
14	350	959	1919	2879	3838	4798	5758
16	400	1253	2507	3760	5013	6267	7520
18	450	1586	3173	4759	6345	7931	9518
20	500	1958	3917	5875	7834	9792	11750
24	600	2820	5640	8460	11280	14100	16921

VR2, VR3, VR4, VR5 RESILIENT SEAT BUTTERFLY VALVES WITH LUGGED CONNECTIONS

Honeywell Building Technologies

In the U.S.:

Honeywell

715 Peachtree Street NE

Atlanta, GA 30308

customer.honeywell.com

® U.S. Registered Trademark
© 2019 Honeywell International Inc.
31-00283EF-01 M.S. 07-19
Printed in United States

Honeywell

Honeywell

Vannes papillon à siège résistant VR2, VR3, VR4 VR5 à raccords à oreilles

DONNÉES TECHNIQUES



CARACTÉRISTIQUES

Tous les modèles

- Tous les modèles
- Disques en acier inoxydable 304
- Corps de vanne en fonte ductile procurant une résistance et une durabilité accrues
- Tige de vanne en acier inoxydable
- Le siège de soupape en EPDM robuste agit aussi comme joint d'étanchéité de bride
- Siège étanche aux bulles à la fermeture
- Taux nominal de fermeture de 200 lb/po² pour les diamètres de 2 à 12 po
- Taux nominal de fermeture de 150 lb/po² pour les diamètres de 14 à 24 po
- Bride de fixation d'actionneur ISO 5211
- Disponible avec interfaces d'actionneur électrique installées en usine à deux positions : commande flottante (trois états) ou à modulation (2-10 V c.c.)
- Contournement manuel sur tous les modèles

- Les actionneurs à sécurité intrinsèque sont disponibles pour les vannes d'un diamètre maximal de 12 po
- Pour eau chaude, refroidie ou de condensation avec un maximum de 60 % de glycol dans les systèmes de CVC

Vannes à 2 voies (VR2)

- Tailles de 2 à 24 po avec raccords à oreilles ANSI de classe 125/150
- Caractéristiques de débit à pourcentage égal modifié
- Système de sécurité à ressort sur les modèles de 2 et 2,5 po et système électronique en option sur les modèles de 3 à 12 po.
- Actionneurs NEMA 2 et NEMA 4X disponibles sur les vannes de 5 po et moins; actionneurs NEMA 4X disponibles sur les vannes de 5 à 24 po

Ensembles de vannes à trois voies (VR3, 4, 5)

- Tailles de 2 à 18 po avec raccords à oreilles ANSI de classe 125/150
- Commande de mélange ou de dérivation
- Caractéristique de débit linéaire modifié
- Raccord en T standard en fonte compris
- Nombreuses configurations de ports convenant à différentes applications
- Système de sécurité à ressort sur les modèles de 2 po et système électronique en option sur les modèles de 2,5 à 12 po
- Actionneurs NEMA 2 et NEMA 4X disponibles sur les vannes de 3 po et moins; actionneurs NEMA 4X disponibles sur les vannes de 3 à 18 po

Table des matières

Caractéristiques	1
Spécifications	2
Plans Dimensionnels	5
Spécifications de l'actionneur	16
Modèles de vanne à 3 voies	18



31-00283EF-01

SPÉCIFICATIONS

REMARQUE : Toutes les spécifications étaient précises au moment de la publication. Honeywell réserve le droit d'améliorer ou d'abandonner des produits sans préavis. Pour obtenir la documentation technique la plus récente, veuillez consulter le site Web <http://customer.honeywell.com>.

Modèles :

Voir le Tableau 1

Dimensions :

Voir la Fig. 1–20

Montage :

pour brides ASME/ANSI de classe 125/150

Types de corps :

Vanne papillon à deux ou trois voies avec raccords à oreilles

Dimensions du corps :

2 voies : 2 à 24 po

3 voies : 2 à 18 po

Caractéristiques de débit :

2 voies : pourcentage égal modifié

3 voies : débit linéaire modifié

Body Static Pressure Rating (maximum):

Conforme à la norme ASME/ANSI classe 125

Pression de service à froid :

232 lb/po²

Pression nominale de fermeture (différentiel maximum) :

Vannes de 2 à 12 po : 200 lb/po²

Vannes de 14 à 24 po : 150 lb/po²

Liquides contrôlés :

Eau chaude ou refroidie contenant jusqu'à 60 % de glycol

Plage de température des liquides :

-30 °C à 121 °C (-22 °F à 250 °F)

Vitesse maximale :

3,7 m/s (12 pi/s)

Matériaux :

Corps :

2 à 6 po et 14 à 24 po : fonte ductile à revêtement poudre d'époxy ASTM A536.

8 à 12 po : fonte ductile à revêtement poudre de polyester ASTM A536

Disque : Acier inoxydable 304

Tige :

2 à 6 po et 14 à 24 po : Acier inoxydable 416

8 à 12 po : Acier inoxydable 420

Siège : EPDM

Joint toriques : EPDM

Douilles :

2 à 6 po et 14 à 24 po : RPTFE

8 à 12 po : bronze, acier, PTFE

Approbations et normes :

Fermeture : conception étanche aux bulles à la pression nominale de fermeture.

Actionneurs de vannes de 12 po et moins : cULus, CE

Actionneurs sur les vannes de 14 po et plus : cCSAus, CE

Températures ambiantes nominales pour l'actionneur :

Voir le Tableau

Accessoires :

MB-IND-1

Indicateur de position, petit

MB-IND-2

Indicateur de position, grand

MB-NSR-SWITCH

Interrupteur auxiliaire NSR DCA

MB-NSR-N4HEAT

Trousse de chauffage NSR

NEMA4 DCA

(Doit être commandée avec la vanne, installé à l'usine)

MB-SR-N4HEAT

Trousse de chauffage SR

NEMA4 DCA

(Doit être commandée avec la vanne, installé à l'usine)

Tableau 1. Sélection de modèle de vanne papillon

Vanne Papillon	Type de raccordement	Motif de corps	Diamètre de vanne	Signal de commande de l'actionneur	Tension d'actionneur	Fonction de sécurité	Tension/rétroaction du contacteur	Caractéristiques nominales NEMA	Description
V	R	Siège résistant ANSI 125/150 (Standard)							
		2	2 voies						
		3	Configurations à 3 voies (voir la Fig. 20)						
		4							
		5							
		5							
		F	2 po (DN 50)						
		G	2,5 po (DN 65)						
		H	3 po (DN 80)						
		J	4 po (DN 100)						
		K	5 po (DN 125)						
		L	6 po (DN 150)						
		M	8 po (DN 200)						
		N	10 po (DN 250)						
		P	12 po (DN 300)						
		R	14 po (DN 350)						
		S	16 po (DN 400)						
		T	18 po (DN 450)						
		U	20 po (DN 500)						
		V	24 po (DN 600)						
		6	Flottant/deux positions (SPDT)						
		7	À modulation analogique (0) 2-10 V c.c.						
		8	Deux positions (SPST)						
		L	24 V c.a./c.c.						
		H	120 V c.a.						
		U	24-240 V c.a./24-125 V c.c.						
		P	Maintien de position en cas de panne						
		S	Ressort de rappel au port A (maître) pour maintien de position ouverte en cas de panne						
T	Ressort de rappel au port A (maître) pour maintien de position fermée en cas de panne								
E	Dispositif de sécurité électronique (position fermée par défaut, modifiable sur place)								
N	Aucune rétroaction								
F	Rétroaction analogique								
S	Interrupteurs auxiliaires intégrés								
B	Rétroaction analogique et interrupteurs auxiliaires								
2	NEMA 2								
4	NEMA 4X								
H	NEMA 4X (avec réchauffeur)								
V	R	2	H	7	L	P	F	2	Exemple : VANNE PAPILLON À SIÈGE RÉSISTANT, 2 VOIES, 3 PO, CV302 FERMETURE 200 LB/PO ² , 24 V C.A., 2 À 10 V C.C., 150 S, SÉCURITÉ INTRINSÈQUE, RÉTROACTION, NEMA2, (Y COMPRIS L'ACTIONNEUR MBP7L4F2/U)

Tableau 2. Sélection de modèle d'actionneur de remplacement de vanne papillon

Type	À sécurité intrinsèque	Régulation	Alimentation	Type d'actionneur	Rétroaction	Nema	Description
MB	Moteur de vanne papillon						
	S	Système de sécurité à ressort					
	E	Système de sécurité électronique					
	P	Maintien de position en cas de panne					
	6	Flottant/2 positions					
	7	À modulation analogique (0)2-10 VDC					
	8	2 positions					
	L	24 V c.a. / V c.c.					
	H	120 V c.a.					
	U	24-240 V c.a. /24-125 V c.c.					
	1	SR 180 lb-po					
	2	NSR 180 lb-po					
	3	SR 180 lb-po					
	A	NSR 180 lb-po					
	4	EFS/FIP 360 lb-po					
	R	EFS/FIP 360 lb-po (VH et VR 3 voies)					
	5	EFS/FIP 800 lb-po					
	6	EFS/FIP 1400 lb-po (vannes de 3, 4, 5, 6 et 12 po)					
	7	EFS/FIP 1400 lb-po (vannes de 8 po)					
	8	EFS/FIP 1400 lb-po (vannes de 10 po)					
	9	FIP 3540 lb-po					
	B	FIP 4425 lb-po					
	C	FIP 5755 lb-po					
	D	FIP 8850 lb-po					
	E	FIP 13275 lb-po					
	F	FIP 17700 lb-po					
	G	FIP 22125 lb-po					
	H	FIP 26550 lb-po					
N	No rétroaction						
F	Rétroaction analogique						
S	Commutateurs auxiliaires intégrés						
B	Comprend des commutateurs auxiliaires et de rétroaction analogique						
2	NEMA 2						
4	NEMA 4X						
H	NEMA 4X (avec RÉCHAUFFEUR)						
MB	S	8	U	1	N	2	Exemple : ACTIONNEUR DE VANNE PAPILLON POUR SÉRIES VR ET VH, RESSORT DE RETOUR, 2 POSITIONS, 24-240 V C.A., 180 LB-PO, NEMA2

REMARQUE : Les tableaux ci-dessus sont destinés à expliquer la signification du système de numérotation de la vanne papillon et de l'actionneur. Il ne s'agit pas d'un outil de configuration du produit. Seuls les numéros de pièce compris dans les catalogues de prix Honeywell peuvent être commandés. Veuillez vous reporter au cpq.honeywell.com pour connaître les configurations disponibles.

PLANS DIMENSIONNELS

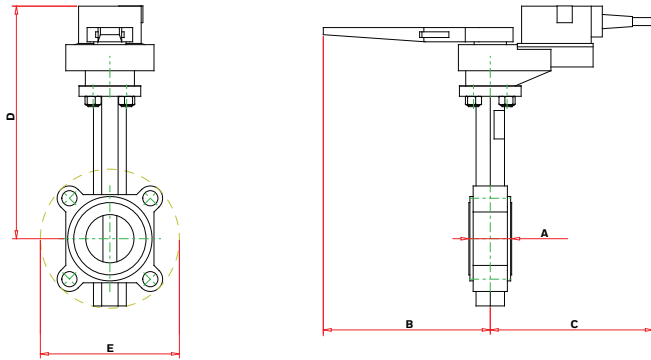

Diam.		Dimensions, po (mm)				
po	DN	A	B	C	D	E
2	50	1,77 (45)	6,93 (176)	6,77 (172)	9,65 (245)	5,77 (147)
2,5	65	1,90 (48)	6,93 (176)	6,77 (172)	10,20 (259)	6,52 (166)

Fig. 1. Vannes à 2 voies avec actionneurs NEMA 2 MBP ... 2,3

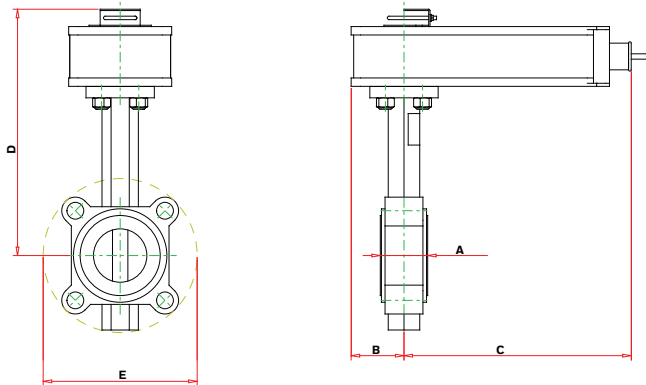

Diam.		Dimensions, po (mm)				
po	DN	A	B	C	D	E
2	50	1,77 (45)	1,98 (50)	8,52 (216)	9,23 (234)	5,77 (147)
2,5	65	1,90 (48)	1,98 (50)	8,52 (216)	9,78 (248)	6,52 (166)

Fig. 2. Vannes à 2 voies avec actionneurs NEMA 2 MBS...3

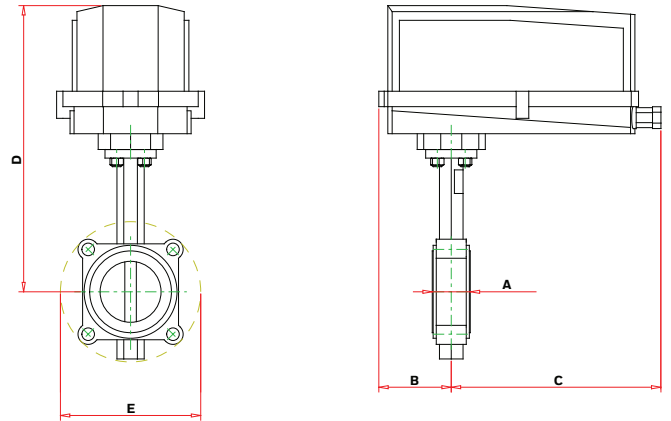

Diam.		Dimensions, po (mm)				
po	DN	A	B	C	D	E
2	50	1,77 (45)	3,62 (92)	10,49 (266)	13,54 (344)	5,77 (147)
2,5	65	1,90 (48)	3,62 (92)	10,49 (266)	14,09 (358)	6,52 (166)
3	80	1,90 (48)	3,62 (92)	10,49 (266)	14,32 (364)	7,02 (178)

Fig. 3. Vannes à 2 voies avec actionneurs NEMA 4 MBP, E...3, 4

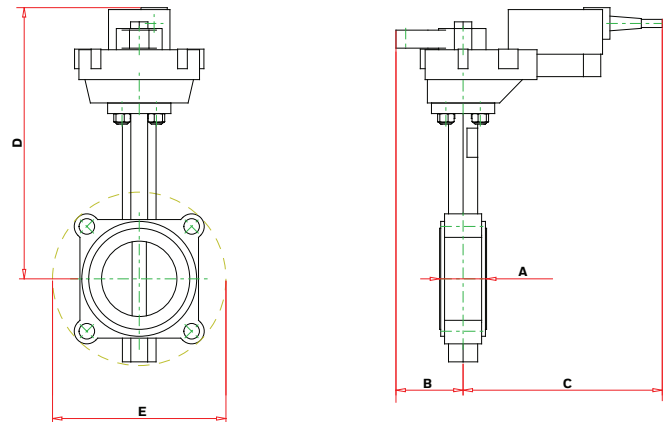

Diam.		Dimensions, po (mm)				
po	DN	A	B	C	D	E
3	80	1,90 (48)	2,72 (69)	8,06 (205)	10,98 (279)	7,02 (178)

Fig. 4. Vannes à 2 voies avec actionneurs NEMA 4 MBP, E...3, 4

VANNES PAPILLON À SIÈGE RÉSIDANT VR2, VR3, VR4 VR5 À RACCORDS À OREILLES

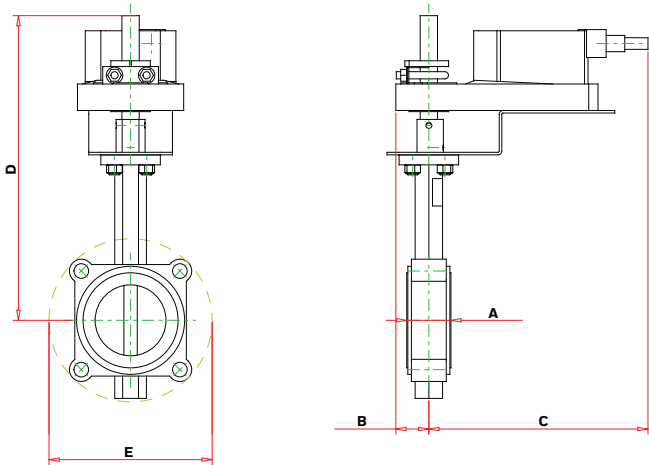

Diam.		Dimensions, po (mm)				
po	DN	A	B	C	D	E
3	80	1,90 (48)	1,42 (36)	9,43 (240)	13,11 (333)	7,02 (178)

Fig. 5. Vannes à 2 voies avec actionneurs NEMA 2 MBE...4

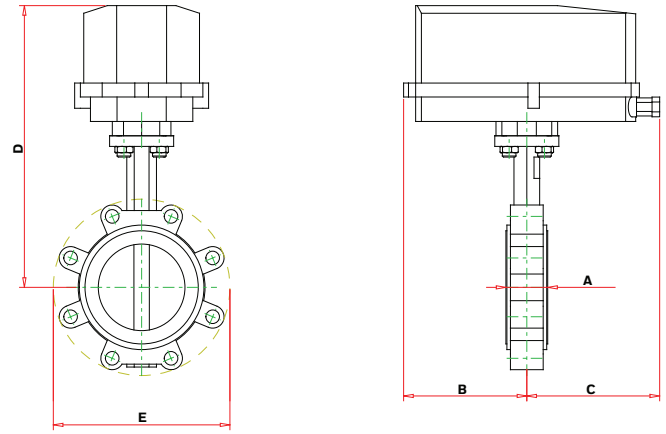

Diam.		Dimensions, po (mm)				
po	DN	A	B	C	D	E
4	100	2,15 (55)	6,81 (173)	7,34 (186)	15,07 (383)	8,52 (216)
5	125	2,31 (59)	6,81 (173)	7,34 (186)	15,59 (396)	9,76 (248)

Fig. 7. Vannes à 2 voies avec actionneurs NEMA 4 MBP, E...5

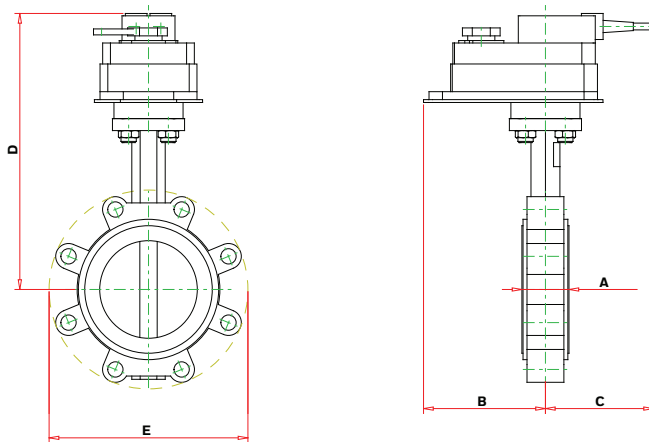

Diam.		Dimensions, po (mm)				
po	DN	A	B	C	D	E
4	100	2,12 (55)	5,99 (152)	5,30 (135)	13,03 (331)	8,52 (216)
5	125	2,31 (59)	5,99 (152)	5,30 (135)	13,55 (344)	9,76 (248)

Fig. 6. Vannes à 2 voies avec actionneurs NEMA 2 MBP, E...5

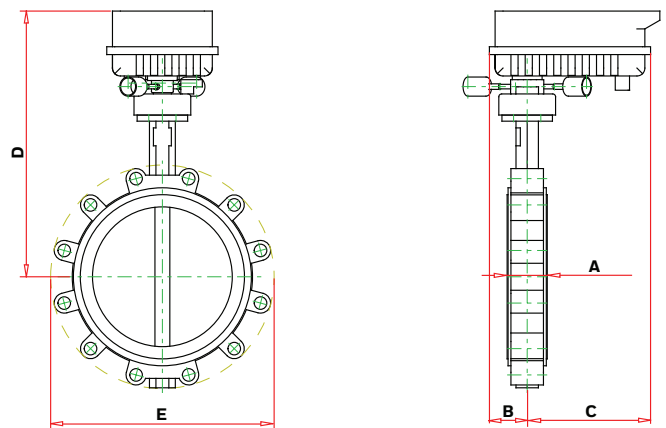

Diam.		Dimensions, po (mm)				
po	DN	A	B	C	D	E
6	150	2,20 (56)	2,65 (67)	9,30 (236)	16,03 (407)	10,76 (273)
8	200	2,36 (60)	2,65 (67)	9,30 (236)	17,37 (441)	13,02 (331)
10	250	2,68 (68)	2,65 (67)	9,30 (236)	18,63 (473)	15,68 (398)
12	300	3,07 (78)	2,65 (67)	9,30 (236)	20,40 (518)	18,40 (467)

Fig. 8. Vannes à 2 voies avec actionneurs MBP...6, 7, 8

VANNES PAPILLON À SIÈGE RÉSIDANT VR2, VR3, VR4 VR5 À RACCORDS À OREILLES

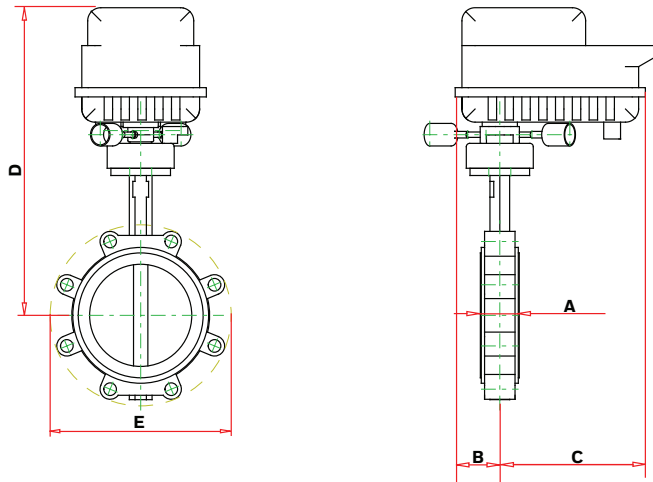

Diam.		Dimensions, po (mm)				
po	DN	A	B	C	D	E
5	125	2,20 (56)	2,65 (67)	9,30 (236)	17,77 (451)	9,76 (248)
6	150	2,20 (56)	2,65 (67)	9,30 (236)	18,28 (464)	10,76 (273)
8	200	2,36 (60)	2,65 (67)	9,30 (236)	19,62 (498)	12,96 (329)
10	250	2,68 (68)	2,65 (67)	9,30 (236)	20,88 (530)	15,66 (398)
12	300	3,07 (78)	2,65 (67)	9,30 (236)	22,65 (575)	18,40 (467)

Fig. 9. Vannes à 2 voies avec actionneurs MBE...6, 7, 8

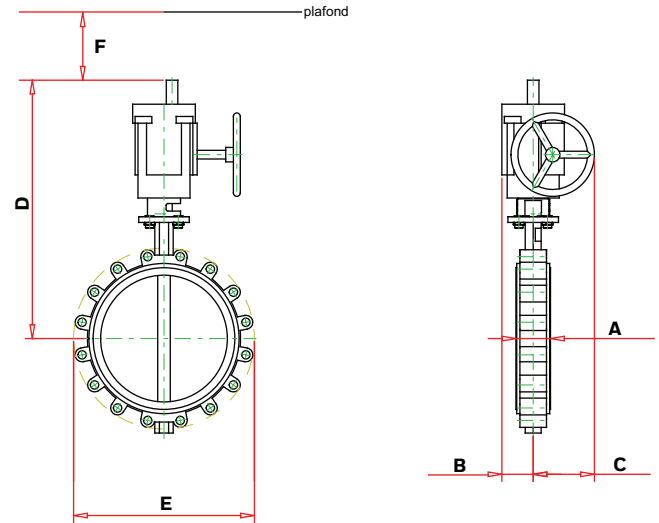

Diam.		Dimensions, po (mm)					
po	DN	A	B	C	D	E	F
14	350	3,22 (82)	4,40 (112)	7,13 (181)	26,97 (685)	20,39 (518)	15,07 (383)
16	400	4,22 (107)	4,40 (112)	7,13 (181)	30,77 (782)	22,89 (581)	16,70 (424)
18	450	4,71 (120)	4,27 (109)	8,35 (212)	35,22 (895)	24,65 (626)	19,87 (505)
20	500	5,25 (133)	4,27 (109)	8,35 (212)	37,50 (953)	26,89 (683)	19,16 (487)
24	600	6,36 (162)	3,18 (81)	14,98 (381)	43,93 (1116)	31,64 (804)	21,66 (550)

Fig. 10. Vannes à 2 voies avec actionneurs MBP...B, C, E, H

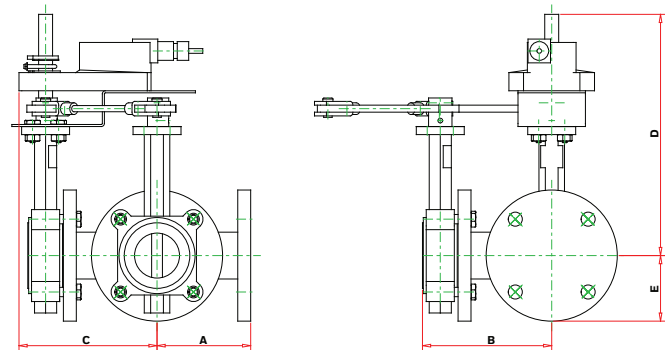

Diam.		Dimensions, po (mm)				
po	DN	A	B	C	D	E
2	50	4,50 (114)	6,27 (159)	6,57 (167)	12,33 (313)	3,00 (76)
2,5	65	5,00 (127)	6,90 (175)	7,37 (187)	12,88 (327)	3,50 (89)

Fig. 11. Vannes à 3 voies avec actionneurs NEMA 2 MBP, E... 2, 3, A, R

VANNES PAPILLON À SIÈGE RÉSIDANT VR2, VR3, VR4 VR5 À RACCORDS À OREILLES

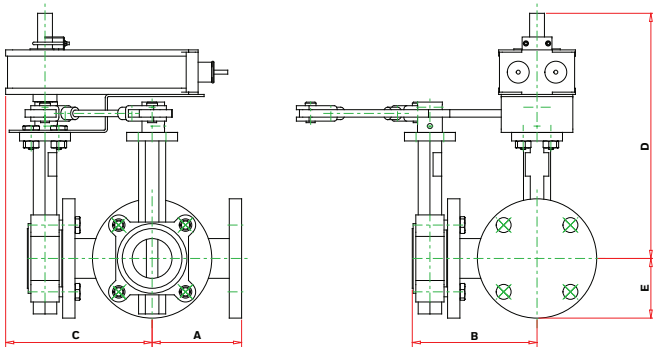

Diam.		Dimensions, po (mm)				
po	DN	A	B	C	D	E
2	50	4,50 (114)	6,27 (159)	7,37 (187)	12,33 (313)	3,00 (76)

Fig. 12. Vannes à 3 voies avec actionneurs NEMA 2 MBS...1, 3

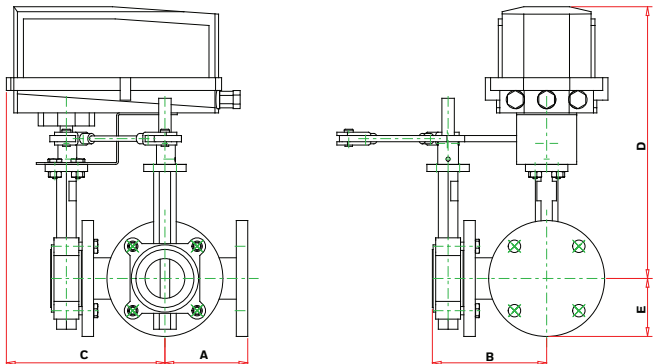

Diam.		Dimensions, po (mm)				
po	DN	A	B	C	D	E
2	50	4,50 (114)	6,27 (159)	9,01 (229)	15,86 (403)	3,00 (76)
2,5	65	5,00 (127)	6,90 (175)	9,57 (243)	16,41 (417)	3,50 (89)

Fig. 13. Vannes à 3 voies avec actionneurs NEMA 4 MBP, E...R

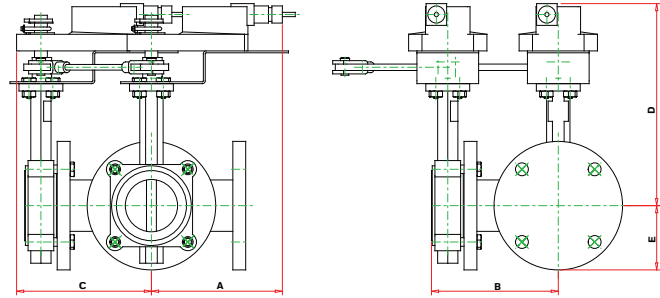

Diam.		Dimensions, po (mm)				
po	DN	A	B	C	D	E
3	80	7,64 (194)	7,40 (188)	7,87 (200)	11,79 (300)	3,75 (95)

Fig. 14. Vannes à 3 voies avec actionneurs NEMA 2 MBP...R

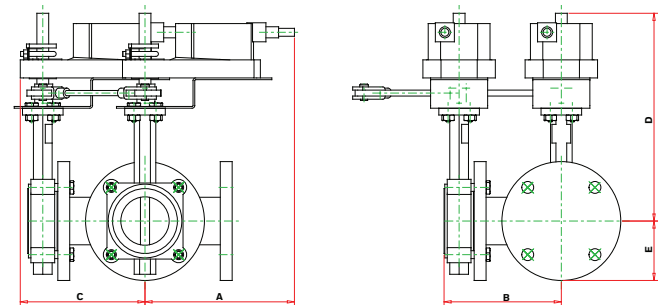

Diam.		Dimensions, po (mm)				
po	DN	A	B	C	D	E
3	80	9,43 (240)	7,40 (188)	7,87 (200)	13,11 (333)	3,75 (95)

Fig. 15. Vannes à 3 voies avec actionneurs NEMA 2 MBE...R

VANNES PAPILLON À SIÈGE RÉSIDANT VR2, VR3, VR4 VR5 À RACCORDS À OREILLES

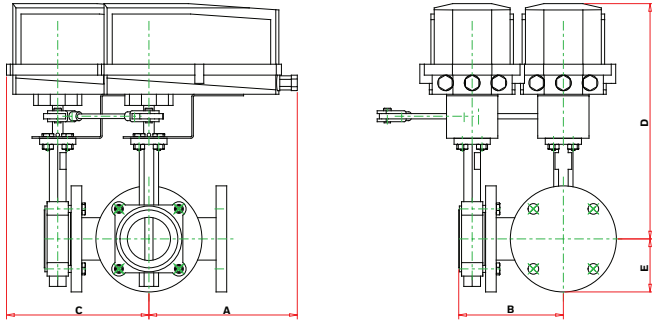

Diam.		Dimensions, po (mm)				
po	DN	A	B	C	D	E
3	80	10,49 (266)	7,40 (188)	10,07 (256)	16,64 (423)	3,75 (95)

Fig. 16. Vannes à 3 voies avec actionneurs NEMA 4 MBP...R

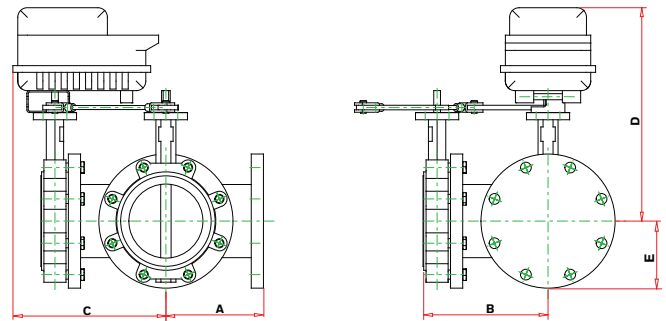

Diam.		Dimensions, po (mm)				
po	DN	A	B	C	D	E
4	100	6,50 (165)	8,55 (217)	11,13 (283)	16,47 (418)	4,50 (114)
5	125	7,50 (191)	9,70 (246)	12,05 (306)	16,99 (432)	5,00 (127)
6	150	8,00 (203)	10,20 (259)	12,55 (319)	17,50 (445)	5,50 (140)
8	200	9,00 (229)	11,36 (289)	13,47 (342)	18,84 (479)	6,75 (172)
10	250	11,00 (279)	13,68 (348)	15,31 (389)	20,10 (511)	8,00 (203)
12	300	12,00 (305)	15,07 (383)	16,12 (409)	21,87 (556)	9,50 (241)

Fig. 18. Vannes à 3 voies avec actionneurs MBE...6, 7, 8

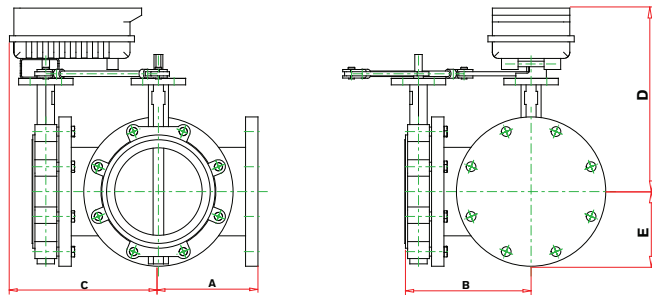

Diam.		Dimensions, po (mm)				
po	DN	A	B	C	D	E
3	80	5,50 (140)	7,56 (192)	8,89 (226)	14,97 (380)	3,75 (95)
4	100	6,50 (165)	8,55 (217)	11,13 (283)	14,22 (361)	4,50 (114)
5	125	7,50 (191)	9,70 (246)	12,05 (306)	14,74 (374)	5,00 (127)
6	150	8,00 (203)	10,20 (256)	12,55 (319)	15,25 (387)	5,50 (140)
8	200	9,00 (229)	11,36 (289)	13,47 (342)	16,59 (421)	6,75 (172)
10	250	11,00 (279)	13,68 (348)	15,31 (389)	17,85 (453)	8,00 (203)
12	300	12,00 (305)	15,07 (383)	16,12 (409)	19,62 (498)	9,50 (241)

Fig. 17. Vannes à 3 voies avec actionneurs MBP...6, 7, 8

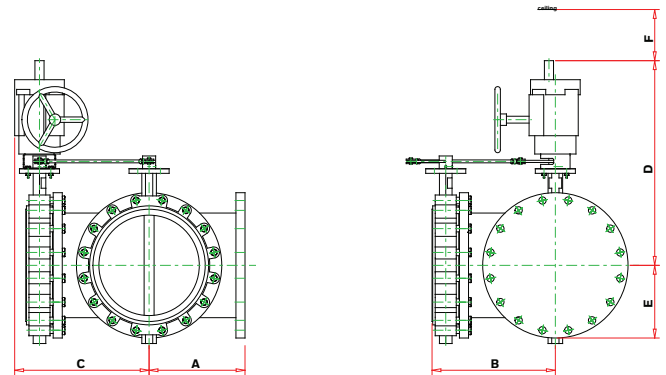

Diam.		Dimensions, po (mm)					
po	DN	A	B	C	D	E	F
14	350	14,00 (356)	17,22 (437)	20,01 (508)	29,51 (750)	10,50 (267)	8,80 (224)
16	400	15,00 (381)	19,22 (488)	21,38 (543)	34,35 (873)	11,75 (299)	8,80 (224)
18	450	16,50 (419)	21,21 (539)	23,13 (588)	35,22 (895)	12,50 (318)	8,80 (224)

Fig. 19. Vannes à 3 voies avec actionneurs MBP...C, D, E

SPÉCIFICATIONS DE L'ACTIONNEUR

Tableau 3. Spécification d'actionneur

Modèle d'actionneur	Couple	Entrées de commande	À sécurité intrinsèque	Tension d'alimentation	Calibrage du transformateur	Température ambiante	Temporisation	Boîtier	Interrupteur auxiliaire				
MBP6L2N2/U	180 lb-po (20 Nm)	2 positions; flottant	Maintien de position en cas de panne	24 V c.a., ±20 %, 50/60 Hz; 24 V c.c., ±10 %	5,5 VA (classe 2)	-30 à 50 °C (-22 à 122 °F)	90 s	IP 54, NEMA 2					
MBP6LAN2/U		Modulation			6 VA (classe 2)		150 s						
MBP7L2F2/U					2 positions		24...240 V c.a., -20 %/+10 %, 50/60 Hz; 24...125 V c.c., ±10 %			7 VA à 24 V c.a. (classe 2); 8,5 VA à 120 V c.a.; 18 VA à 240 V c.a.	-30 à 50 °C (-22 à 122 °F)	moins de 75 s	IP 54, NEMA 2
MBP7L3F2/U													IP 54, NEMA 2
MBS8U1N2/U	180 lb-po (20 Nm)	2 positions	Système de sécurité à ressort (<20 s)	24 V c.a., ±20 %, 50/60 Hz; 24 V c.c., -10 %/+20 %	10 VA (classe 2)	-30 à 50 °C (-22 à 122 °F)	150 s	IP 54, NEMA 2	2 x SPDT*				
MBS8U3N2/U								IP 54, NEMA 2					
MBS8U3N4/U								IP 66/67 NEMA 4X					
MBS8U3S2/U								IP 54, NEMA 2					
MBS8U3S4/U								IP 66/67 NEMA 4X					
MBS7L1F2/U								Modulation		24 V c.a., ±20 %, 50/60 Hz; 24 V c.c., ±10 %	24 V c.a., ±20 %, 50/60 Hz; 24 V c.c., ±10 %	10 VA (classe 2)	-30 à 50 °C (-22 à 122 °F)
MBS7L3F2/U	IP 54, NEMA 2												
MBS7L3F4/U	IP 66/67 NEMA 4X												
MBS7L3B2/U	IP 54, NEMA 2												
MBS7L3B4/U	IP 66/67 NEMA 4X												
MBP6L4N2/U	360 lb-po (40 Nm)	2 positions; flottant	Maintien de position en cas de panne	24 V c.a., ±20 %, 50/60 Hz; 24 V c.c., ±10 %	6 VA (classe 2)	-30 à 50 °C (-22 à 122 °F)	150 s	IP 54, NEMA 2					
MBP6LRN2/U					Modulation		7 VA (classe 2)	35 s		IP 66/67 NEMA 4X			
MBP6L4N4/U								150 s		IP 54, NEMA 2			
MBP6LRN4/U		IP 66/67 NEMA 4X											
MBP7L4F2/U		IP 54, NEMA 2											
MBP7LRF2/U		Modulation			24 V c.a., ±20 %, 50/60 Hz; 24 V c.c., ±10 %		21 VA (classe 2)	-30 à 50 °C (-22 à 122 °F)		150 s	IP 54, NEMA 2		
MBP7L4F4/U											IP 66/67 NEMA 4X		
MBP7LRN4/U	IP 66/67 NEMA 4X												
MBE6L4N2/U	360 lb-po (40 Nm)	2 positions; flottant	Système de sécurité électronique (35 s)	24 V c.a., ±20 %, 50/60 Hz; 24 V c.c., ±10 %	21 VA (classe 2)	-30 à 50 °C (-22 à 122 °F)	150 s	IP 54, NEMA 2					
MBE6LRN2/U								Modulation		IP 66/67 NEMA 4X			
MBE6L4N4/U										IP 54, NEMA 2			
MBE7L4F2/U		Modulation						IP 66/67 NEMA 4X					
MBE7L4F4/U								IP 66/67 NEMA 4X					

* 3 A résistive (0,5 A inductive) à 250 V c.a., un réglage à 10°, un réglage de 10 à 90°

** 3 A résistive (0,5 A inductive) à 250 V c.a., un réglage à 10°, un réglage à 85°

Tableau 3. Spécification d'actionneur

Modèle d'actionneur	Couple	Entrées de commande	À sécurité intrinsèque	Tension d'alimentation	Calibrage du transformateur	Température ambiante	Temporisation	Boîtier	Interrupteur auxiliaire
MBP6L5N2/U	800 lb-po (90 Nm)	2 positions; flottant	Maintien de position en cas de panne	24 V c.a., ±20 %, 50/60 Hz; 24 V c.c., ±10 %	12 VA (classe 2)	-30 à 50 °C (-22 à 122 °F)	35 s	NEMA 1	
IP 66/67 NEMA 4X									
Modulation		150 s					NEMA 1		
							IP 66/76 NEMA 4X		
MBE6L5N2/U	800 lb-po (90 Nm)	2 positions; flottant	Système de sécurité électronique (35 s)	24 V c.a., ±20 %, 50/60 Hz; 24 V c.c., ±10 %	21 VA (classe 2)	-30 à 50 °C (-22 à 122 °F)	150 s	NEMA 1	
IP 66/67 NEMA 4X									
Modulation		150 s					NEMA 1		
							IP 66/67 NEMA 4X		
MBP6U6SH/U	1400 lb-po (160 Nm)	2 positions; flottant	Maintien de position en cas de panne	24...240 V c.a., -20%/+10 %, 50/60 Hz; 24...125 V c.c., -20%/+10 %	20 VA à 24 V c.a./c.c. (classe 2); 23 VA à 120 V c.a./c.c.; 52 VA à 230 V c.a.	-30 à 50 °C (-22 à 122 °F)	35 s	IP 66/67 NEMA 4X avec réchauffeur	2 x SPDT*
MBP6U7SH/U									
MBP6U8SH/U									
MBP7U6BH/U		Modulation							
MBP7U7BH/U									
MBP7U8BH/U									
MBE6U6SH/U	1400 lb-po (160 Nm)	2 positions; flottant	Système de sécurité électronique (30 s)	24...240 V c.a., -20%/+10 %, 50/60 Hz; 24...125 V c.c., -20%/+10 %	55 VA à 24 V c.a./c.c. (classe 2); 43 VA à 120 V c.a./c.c.; 68 VA à 230 V c.a.	-30 à 50 °C (-22 à 122 °F)	35 s	IP 66/67 NEMA 4X avec réchauffeur	2 x SPDT*
MBE6U7SH/U									
MBE6U8SH/U									
MBE7U6BH/U		Modulation							
MBE7U7BH/U									
MBE7U8BH/U									
MBP6LBSH/U	4425 lb-po (500 Nm)	2 positions	Maintien de position en cas de panne	24 V c.a., ±10 %, 50/60 Hz, 24 V c.c., ±10 %	214 VA	-30 à 65 °C (-22 à 150 °F)	26 s	IP 66/67 NEMA 4X avec réchauffeur	2 x SPDT**
MBP7LBBH/U		Modulation							
MBP6HCSH/U	5755 lb-po (650 Nm)	2 positions	Maintien de position en cas de panne	120 V c.a., ±10 %, 50/60 Hz	288 VA	-30 à 65 °C (-22 à 150 °F)	34 s	IP 66/67 NEMA 4X avec réchauffeur	2 x SPDT**
MBP7HCBH/U		Modulation			240 VA		38 s		
MBP6HDSH/U	8850 lb-po (1000 Nm)	2 positions			504 VA		50 s		
		Modulation			240 VA		59 s		
MBP6HESH/U	13275 lb-po (1500 Nm)	2 positions			504 VA		51 s		
		Modulation			336 VA		79 s		
MBP7HEBH/U	26550 lb-po (3000 Nm)	2 positions			432 VA		62 s		
		Modulation			516 VA		71 s		

* 3 A résistive (0,5 A inductive) à 250 V c.a., un réglage à 10°, un réglage de 10 à 90°

** 3 A résistive (0,5 A inductive) à 250 V c.a., un réglage à 10°, un réglage à 85°

Tableau 4. Duty Cycle on High Torque Actuators

Modèle d'actionneur	Couple	Entrées de commande	Duty Cycle
MBP6LBSH/U	4425 lb-po [500 Nm]	2 positions	75%
MBP7LBBH/U		Modulation	
MBP6HCSH/U	5755 lb-po [650 Nm]	2 positions	30%
MBP7HCBH/U		Modulation	75%
MBP6HDSH/U	8850 lb-po [1000 Nm]	2 positions	30%
MBP7HDBH/U		Modulation	75%
MBP6HESH/U	13275 lb-po [1500 Nm]	2 positions	30%
MBP7HEBH/U		Modulation	75%
MBP6HSH/U	26550 lb-po [3000 Nm]	2 positions	30%
MBP7HHBH/U		Modulation	50%

Modèles de vanne à 3 voies

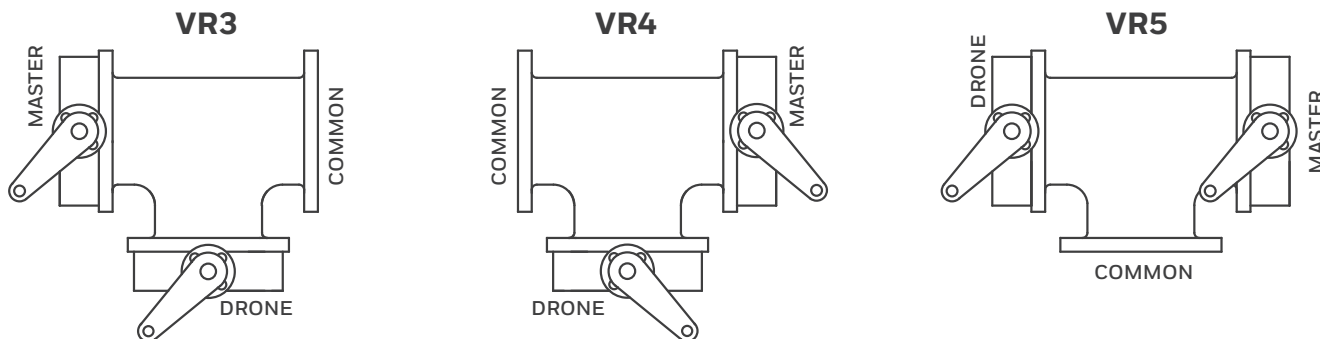

Fig. 20. Configurations de vanne à 3 voies

Données d'écoulement

Tableau 5. Cv de la vanne

Diamètre de vanne		Cv								
po	DN	10°	20°	30°	40°	50°	60°	70°	80°	90°
2	50	0.06	3	7	15	27	44	70	105	115
2.5	65	0.1	6	12	25	45	75	119	178	196
3	80	0.2	9	18	39	70	116	183	275	302
4	100	0.3	17	36	78	139	230	364	546	600
5	125	0.5	29	61	133	237	392	620	930	1022
6	150	0.8	45	95	205	366	605	958	1437	1579
8	200	2	89	188	408	727	1202	1903	2854	3136
10	250	3	151	320	694	1237	2047	3240	4859	5340
12	300	4	234	495	1072	1911	3162	5005	7507	8250
14	350	6	338	715	1549	2761	4568	7230	10844	11917
16	400	8	464	983	2130	3797	6282	9942	14913	16388
18	450	11	615	1302	2822	5028	8320	13168	19752	21705
20	500	14	791	1674	3628	6465	10698	16931	25396	27908
24	600	22	1222	2587	5605	9989	16528	26157	39236	43116

Tableau 6. Débit

Diamètre de vanne		Débit en gal/min					
po	DN	2 pi/s	4 pi/s	6 pi/s	8 pi/s	10 pi/s	12 pi/s
2	50	19	39	59	78	98	117
2.5	65	30	61	92	122	153	184
3	80	44	88	132	176	220	264
4	100	78	157	235	313	392	470
5	125	122	245	367	490	612	734
6	150	176	352	529	705	881	1058
8	200	313	627	940	1253	1567	1880
10	250	490	979	1469	1958	2448	2738
12	300	705	1410	2115	2820	3525	4230
14	350	959	1919	2879	3838	4798	5758
16	400	1253	2507	3760	5013	6267	7520
18	450	1586	3173	4759	6345	7931	9518
20	500	1958	3917	5875	7834	9792	11750
24	600	2820	5640	8460	11280	14100	16921

VANNES PAPILLON À SIÈGE RÉSISTANT VR2, VR3, VR4 VR5 À RACCORDS À OREILLES

VANNES PAPILLON À SIÈGE RÉSISTANT VR2, VR3, VR4 VR5 À RACCORDS À OREILLES

Honeywell Building Technologies

In the U.S.:

Honeywell

715 Peachtree Street NE

Atlanta, GA 30308

customer.honeywell.com

® U.S. Registered Trademark
© 2019 Honeywell International Inc.
31-00283EF-01 M.S. 07-19
Printed in United States

Honeywell