

**Data Book**

DB\_CV\_x-AV3-i-G02-DW\_102022\_EN\_rev00

# x-AV3-i-DW

# x-AV3-i-DW DF

# x-AV3-i-DW FC

FULL INVERTER direct expansion air conditioners for IT Cooling.



The picture of the unit is indicative and may vary depending on the model

- PERIMETER INSTALLATION
- FULLY HERMETIC BLDC INVERTER COMPRESSORS
- SINGLE OR DOUBLE REFRIGERANT CIRCUIT
- AIR DELIVERY FROM THE BOTTOM OR FROM THE TOP
- PLUG FANS WITH EC ELECTRIC MOTOR
- DUAL FLUID / FREE COOLING SYSTEM
- ELECTRONIC EXPANSION VALVE
- AIR SUCTION UP TO 40°C

CERTIFICATIONS	4
GENERAL CHARACTERISTICS	5
INSTALLATION	7
PRODUCT FEATURES AND BENEFITS	8
F-GAS DIRECTIVE	8
IDENTIFICATION	8
STORAGE AND SHIPMENT TEMPERATURE	8
OPERATION LIMITS	9
THE SERIES	10
COMPONENTS OF THE UNIT	11
MAIN COMPONENTS	11
DRY COOLER	13
STANDARD EQUIPMENT	14
TECHNICAL DATA	15
REFRIGERANT CHARGE	16
DUAL FLUID SYSTEM	18
FREE COOLING SYSTEM	18
WATER QUALITY OF THE HYDRAULIC CIRCUITS	20
ANTIFREEZE MIXTURES	21
REFRIGERANT SCHEME	22
ACUSTIC DATA	27
ELETRIC DATA	28
MICROPROCESSOR CONTROL SYSTEM	29
ACCESSORIES	33
ACCESSORY: B263 – OVER AIR DELIVERY – BOTTOM INTAKE	35
ACCESSORY: B266 – FRONT AIR DELIVERY – TOP INTAKE	35
ACCESSORY: B680 – CLOSING BASEMENT	35
ACCESSORY: 601 – LIQUID LINE SOLENOID VALVE	36
ACCESSORY: A547 – COSTANT AIR FLOW	36
ACCESSORY: A548 – CONSTANT PRELEVANCE	36
ACCESSORY: B793 – POWER SUPPLY 400/3+N/50	36
ACCESSORY 383 – NUMBERED WIRINGS + UK REQUESTS	36
ACCESSORY: A842 – WITH NETWORK ANALYZER	37
ACCESSORY: P111 – DUAL POWER SUPPLY	37
ACCESSORY: P113 – KIT DUAL POWER SUPPLY	37
ACCESSORY: 4180 – WITOUT SERIAL CARD	38
ACCESSORY: 4181 – SERIAL CARD MODBUS	38
ACCESSORY: 4182 – SERIAL CARD LON	38
ACCESSORY: 4184 – SERIAL CARD BACNET MS/TP RS485	38
ACCESSORY: 4185 – SERIAL CARD BACNET OVER IP	38
ACCESSORY: 6461 – HPC (ONLY DUAL FLUID VERSION)	39
ACCESSORY: 1441 – KIPLINK + COMPACT KEYBOARD	41
ACCESSORY: 1442 – KIPLINK + 7 INCH TOUCH SCREEN	41
ACCESSORY: 6192 – COMPACT KEYBOARD	41
ACCESSORY: 6196 – KIPLINK	41

ACCESSORY: 6195 – COMPACT 7 INCH TOUCH SCREEN	42
ACCESSORY: C9261063 – REMOTE DISPLAY	43
ACCESSORY: P151 – LOWERED DISPLAY PER UNDER	43
ACCESSORY: A492 - LEAKAGE DETECTOR + ADDITIONAL RECEIVER	43
ACCESSORY: A501 – CLOGGED FILTER SENSOR	43
ACCESSORY: A511 - SMOKE SENSOR	43
ACCESSORY: A521– FIRE SENSOR	44
ACCESSORY: B811 – AIR FLOW SENSOR	44
ACCESSORY: 4503 - FAST RESTART (ULTRACAP)	44
ACCESSORY: 2412 - CONTROL PHASE SEQUENCE + CONTROL TENSION	44
ACCESSORY: A381 – KIT CONDENSATE DRAIN PUMP	45
ACCESSORY: A812 – WHIT DIRECT FREE COOLING	45
ACCESSORY: A791 – AIR TEMPERATURE CONTROL ON SUCTION AIR	45
ACCESSORY: B803 - 3 WAY VALVE (ONLY DUAL FLUID VERSION)	46
ACCESSORY: B807 - 2-WAY VALVE EPIV	47
ACCESSORY: P201 – 2 WAY VALVE	47
ACCESSORY: A431 – ELECTRIC HEATERS	48
ACCESSORY: P051- DEUMIDIFICATION FUNCTION	48
ACCESSORY: 4303 - HUMIDIFIER VAP. 8 KG/H UM08	48
ACCESSORY: 4305 - HUMIDIFIER VAP. 15 KG/H UM15	48
ACCESSORY: P161 - T/RH PROBE AIR SUCTION	49
ACCESSORY: P071 - T/RH REMOTE PROBE (1 PROBE)	50
ACCESSORY: P072 - T/RH REMOTE PROBE (2 PROBES)	50
ACCESSORY: P073 - T/RH REMOTE PROBE (3 PROBES)	50
ACCESSORY: P074 - T/RH REMOTE PROBE (4 PROBES)	50
ACCESSORY: P080 – WITHOUT AIR FILTER	50
ACCESSORY: P084 - EPM10 50% AIR FILTER	50
ACCESSORY: P101 – KIT ANTI-SEISMIC ANCHOR	51
ACCESSORY: PLENUM	52
OPTIONAL ACCESSORY: A531 - DAMPER ON-OFF	58
OPTIONAL ACCESSORY: B981 - SUPPORTING FRAME H 350 – 500 MM	59
OPTIONAL ACCESSORY: B982 - SUPPORTING FRAME H 500 - 750 MM	59
OPTIONAL ACCESSORY: B983 - SUPPORTING FRAME H 750 - 1000 MM	59
OPTIONAL ACCESSORY: B991 – INSULATION	60
UNIT DRAWING	61
OVERHEAD FLOOR DRILLING FOR MACHINES UNDER	67
EXAMPLES OF MACHINE NOISE CALCULATION	69
AIR FILTER EXTRACTION	71
SHIPMENT: DIMENSIONS	72
SHIPMENT: WEIGHT	72
SHIPMENT: ACCESSORIES - DIMENSION AND WEIGHT	73

**Liability disclaimer**

This publication has been prepared for information purposes only and does not constitute a binding offer by Mitsubishi Electric. Mitsubishi Electric has compiled the contents of this publication to the best of its knowledge. The information contained in this publication is subject to change without notice. Mitsubishi Electric expressly disclaims any liability for any direct or indirect damage, in the broadest sense, arising out of or in connection with the use and/or interpretation of this publication. All contents are copyrighted by Mitsubishi Electric.



## ISO 9001 CERTIFICATION

Quality Management System



## ISO 14001 CERTIFICATION

Environmental Management System



## BS OHSAS 18001 CERTIFICATION

Occupational Health and Safety Management System

## PRODUCT CERTIFICATIONS BY COUNTRY



## CE MARKING

## INTRODUCTION

The direct expansion perimeter unit has been designed following a path aimed at satisfying specific requirements such as ease of installation, total front accessibility, and especially performance. These results were made possible by MEHITS' experience of more than 50 years in the field of IT Cooling.

This solution is ideal for cooling IT equipment with small to medium thermal loads (< 1000 kW), typically Enterprise, Edge and Colocation Data Centers but also battery rooms and UPSs. The entire range offers a wealth of configuration possibilities thanks to the large number of accessories and versions available.

The available versions are shown here. For ease of reference, 2 Databooks have been created comprising two groups:

### DX / DX DF

#### Direct Expansion - DX



### DW / DW FC / DW DF

#### Direct Expansion, water cooled - DW



#### Dual Fluid - DX DF



#### Direct Expansion, water cooled - FC coil - DW FC



#### Dual Fluid - DW DF



## FULL INVERTER Air conditioners for IT Cooling

- Direct expansion, water-cooled;
- Equipped with built-in water-cooled condenser;
- Inverter driven BLDC compressors for modulating cooling capacity in response to data centre load variations;
- Plug fans of proprietary design with external rotor EC electric motors;
- Single or dual cooling circuit.
- Available in Dual Fluid version: the unit includes a chilled water coil in addition to the direct expansion coil.
- Available in DW FC version: the unit includes a free-cooling coil in addition to the direct expansion coil.

The series, for perimeter installation, consists of 10 models available in the following versions:

- Air delivery upwards (Over) with air intake from the front through a honeycomb grille and air delivery upwards.
- Air supply downwards (Under) with air intake from the top of the machine and air supply downwards.

Cooling capacity: 30 ÷ 140 kW

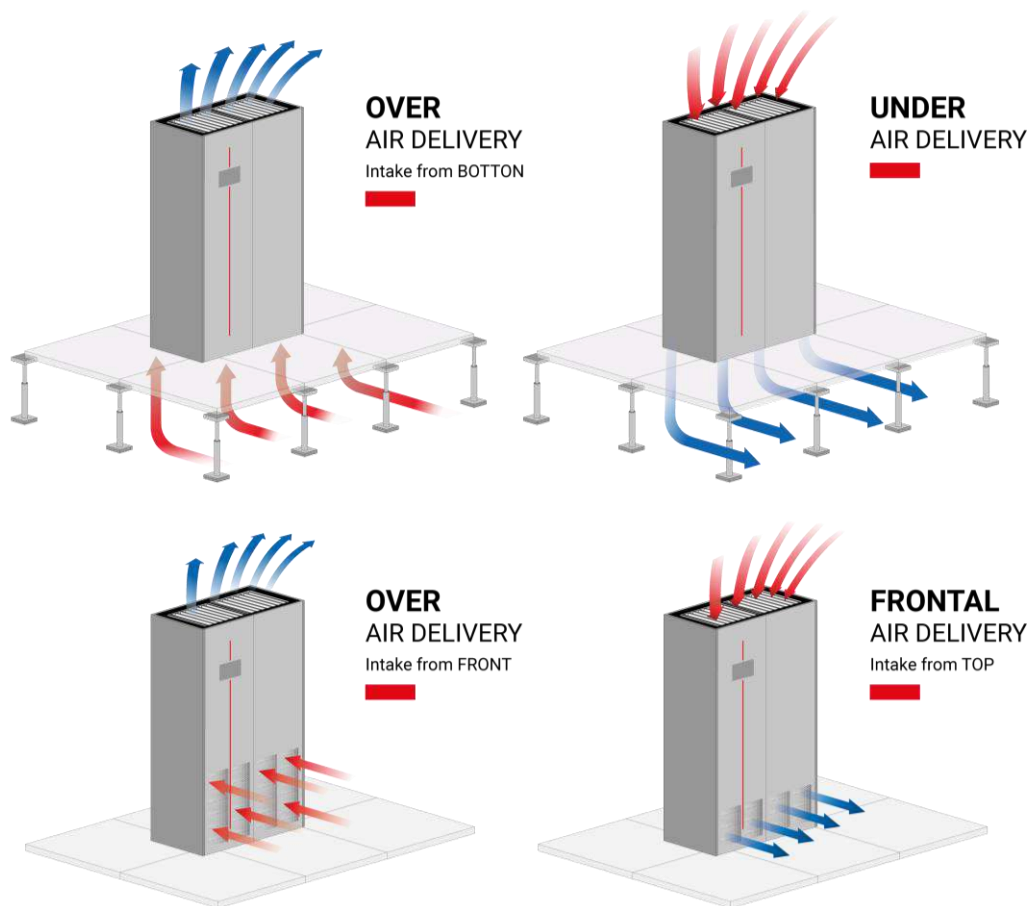

The machines are designed for internal installation. Construction solutions and internal layout allow high application flexibility and front access to the main components for inspection and routine maintenance.

The units require refrigerant gas charging, electrical and hydraulic connections. End-of-line test consisting of a functional test with reading and monitoring of operating parameters, alarm simulation, visual inspection.

## INSTALLATION



### UNDER AIR SUPPLY (U - UNDER)

Application suitable for server racks with ventilated front and rear doors. The typical installation is a perimeter installation, the units are placed along the walls of the room. Air distribution is from below, via the plenum formed by the floor of the building and the raised floor. This solution is normally used in hi-tech air conditioning and is particularly suitable when the thermal load is distributed evenly in all areas of the room. The air is distributed by means of special diffusion tiles positioned in front of the row of racks. Hot air is expelled to the rear of the racks. For optimal installation, it is advisable to provide compartmentalisation of the cold aisle.



### OVER AIR SUPPLY (O - OVER)

Application suitable for server racks with ventilated front and rear doors. The typical installation is a perimeter installation, the units are placed along the walls of the room. Air distribution is from the top of the unit directly into the room or via plenum or ducting. It is possible, through the application of a plenum with grilles on the supply air of the unit, to direct the flow through the adjustable fins of the grilles. The system is normally applied in installations where it is not possible to provide a raised floor. On request, in order to limit the acoustic dissipation in the environment, it is possible to supply a closing panel on the bottom, made of hot-galvanised sheet steel insulated with a special sound-absorbing material. This option is particularly suitable for installations on special floors (raised floors, wooden floors, etc.). The basement closing panel is supplied assembled inside the basement and does not change the dimensions of the unit.

## UNDER (M - L - XL)

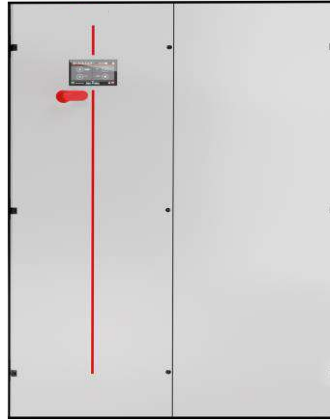
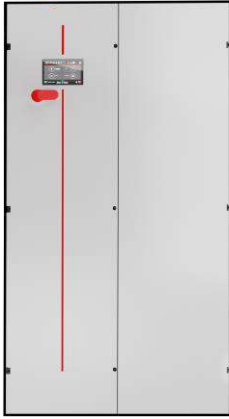

## OVER (M - L - XL)

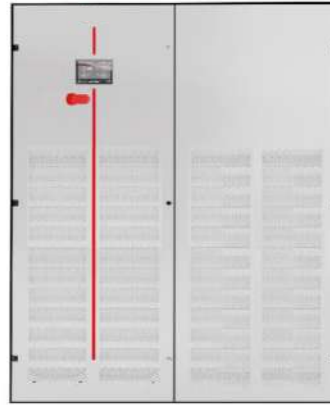
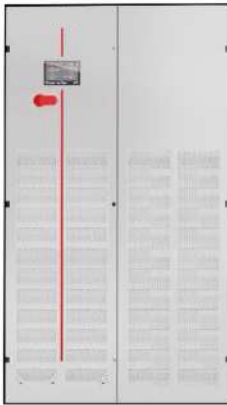



## PRODUCT FEATURES AND BENEFITS

- Different compressors per circuit, with single BLDC inverter compressor or BLDC inverter compressor in combination with ON/OFF compressor, ensure maximum energy efficiency in all operating conditions
- New Plug Fans of proprietary design with EC electric motors and composite material impeller (with recycled polymer base) ensuring reduced power consumption
- New maintenance-free fan motors;
- Fully modulating, able to follow the load increase of the data centre;
- Improved control software with advanced logic;
- Single or dual cooling circuit;
- Intake air temperature up to 40°C.

## F-GAS DIRECTIVE

The units highlighted in this publication contain the fluorinated greenhouse gas <HFC R410A [GWP100 2088]>.

## MODEL IDENTIFICATION

### Air conditioners for IT Cooling

Model: x-AV3-i-G02-DW-O-029

<b>x-AV3</b>	<b>Serie</b>
<b>-i-</b>	<b>Compressor type</b> i = inverter f = fixed speed
<b>-G02-</b>	<b>Refrigerant R410A</b>
<b>-DW-</b>	<b>Version</b> DX = direct expansion DF = Dual Fluid: direct expansion + chilled water coil DW = direct expansion, water cooled DW FC = direct expansion + FC coil, water cooled DW DF = Dual Fluid: direct expansion + chilled water coil, water cooled
<b>-O-</b>	<b>Air supply</b> O = over air supply U = under air supply
<b>-029-</b>	<b>Model / Cooling capacity (kW)</b>

## TRANSPORT AND STORAGE TEMPERATURE

During transport and if the machine is not installed on receipt, place it in its packaging in a closed, dry and sun-protected environment at a temperature between -30°C and 45°C with no surface condensation.

**OPERATING LIMITS**

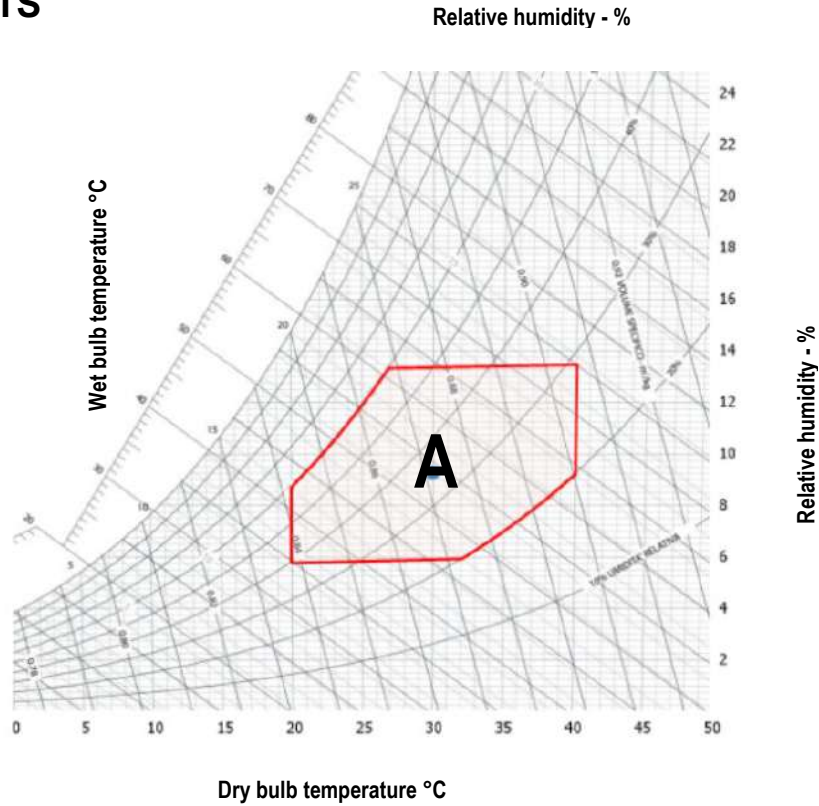

**ROOM AIR CONDITIONS**

Room air temperature:

- 12,5°C                    minimum temperature with wet bulb.
- 24,5°C                    maximum temperature with wet bulb.
- 20°C                        minimum temperature with dry bulb.
- 40°C                        maximum temperature with dry bulb..

AREA "A". Unit operating envelope.

Room air humidity:

- 20%UR                    minimum relative humidity.
- 60%UR                    maximum relative humidity

**WATER CONDENSER**

Inlet water temperature

- 6-20°C Inlet water temperature range - the use of the 2-way valve accessory for condensation control is required.
- 20-50°C Inlet water temperature range - without necessarily using the 2-way valve accessory for condensation control.

Outlet water temperature

- 25-55°C Outlet water temperature range

ΔT of operation:

- 3-20°C ΔT of operation between water inlet/outlet

**COOLED WATER TEMPERATURE (Free-Cooling Circuit)**

Inlet water temperature

- 6 - 25 °C Inlet water temperature range
- ΔT 3 - 10 °C Permissible temperature difference range water inlet-outlet

All values are to be considered as indicative. Operating temperatures are influenced by a number of variables such as:

- Operating conditions;
- Refrigeration load;
- Microprocessor control settings.

## HYDRAULIC CIRCUIT

$\Delta P$  5-150 kPa Pressure drop range for Free-Cooling hydraulic circuit

16 bar Maximum operating pressure of hydraulic circuit

## POWER SUPPLY

$\pm 10\%$  Maximum supply voltage tolerance (V)

$\pm 2\%$  Maximum unbalance between phases

## MAIN COMPONENTS



### FRAMEWORK

- The structure is designed to ensure complete frontal accessibility of all components requiring adjustment and routine maintenance.
- Internal sheet steel panelling with protective surface treatment according to UNI ISO 9227/ASTMB117 and ISO 7253.
- Front aesthetic panels colour RAL 9006 with wrinkled finish, hinged with quick release system to simplify removal.
- Side and rear aesthetic panels colour RAL 7016 with wrinkled finish, fully removable.
- Panelling insulated internally with polyurethane foam mat
- Air flow OVER version:
  - Air intake from the front through honeycomb grille and air flow upwards
  - Air intake from the bottom base and air discharge to the top
- Air flow UNDER version
  - Air intake from the top and air supply downwards.
  - Air intake from above and air discharge to the front with basement closure.
- Containment compartment for electrical panel on front side for direct access to adjustment and control components;



### FILTER SECTION

- Air filters with 60% COARSE efficiency (according to ISO EN 16890), with synthetic fibre filter media for high aeraulic efficiency.
- Access to air filters:
  - OVER version
    - for all machines front access
  - UNDER version
    - for all machines filter extraction from the top
- Dirty filter sensor for signalling via air-side differential pressure switch



### BLDC COMPRESSOR SECTION

For unit sizes M (all sizes), L (052), XL (078-090):

- BLDC inverter driven scroll compressors for refrigerant R410A
- Inverter driven brushless synchronous motor
- Driver for compressor speed modulation in response to changes in cooling demand
- Reactor for noise and electromagnetic interference reduction

For unit sizes L (067-076) and XL (108-140):

- One BLDC inverter compressor + one on/off compressor per refrigerant circuit
- On/off compressor features:
  - ON/OFF scroll compressor with spiral profile optimised for refrigerant R410A.
  - Three-phase 2-pole electric motor with direct starting.

FOR ALL COMPRESSORS:

- Crankcase heater for each compressor
- Acoustic insulation hood for each compressor to reduce the sound level of the unit.
- Anti-vibration rubber mounts



### FAN SECTION

The fan section is contained within the machine and comprises:

- Centrifugal fans with backward curved blades of proprietary design, without scroll (Plug-Fan), directly coupled to external rotor electric motor.
- Impeller made of composite material with 100% recycled polymer base.
- Brushless type EC synchronous electric motor with integrated electronic commutation system with continuous speed variation. Motor speed regulation is achieved via the "EC" (Electronic Commutation) system, which controls the motor based on a signal from the microprocessor control.

- Fan control via ModBus. In the event of a fault, the control stops the fan concerned, indicating the type of fault. A machine with more than one fan is not stopped.
- Adjustable head.



## COOLING SECTION – DIRECT EXPANSION COIL

### M and L size units:

- All-aluminium micro-channel evaporator, a solution that allows the refrigerant charge in the circuit to be kept to a minimum and reduces the pressure drop on the air side of the machine, thus increasing the overall efficiency of the unit
- Peraluman coil support frame with integrated filter support
- Peraluman condensate water collector with flexible PVC drain.
- Intake and supply air temperature probes for regulating and monitoring unit operation.
- Flood sensor (with positioning on the room floor) for alarm indication in case of water presence.

### XL size unit:

- Finned pack heat exchanger with copper tubes and high-efficiency aluminium fins, specifically developed to guarantee a high heat exchange coefficient and low pressure drops.
- Filter support frame upstream of the evaporator
- Peraluman condensate collector with flexible PVC drain.
- Intake and supply air temperature probes for regulating and monitoring machine operation.
- Flood sensor (with positioning on the room floor) for alarm indication in the event of water presence.



## COOLING SECTION - COOLED WATER BATTERY (Dual Fluid / Free Cooling system)

- 4-row water cooling coil with copper tubes, aluminium finning and hot-dip galvanised sheet metal frame.
- Motorised 2-way valve with 0-10 VDC control and emergency manual override
- Temperature probe on water inlet
- Copper water pipes with anti-condensation insulation

## CONDENSING SECTION

- Water-cooled condenser of the soldered plate type, with corrugated plates and connections in AISI 316 and Cu brazing material.
- 0÷10V proportional signal for condensation control.

## REFRIGERANT CIRCUIT

- Components for each refrigerant circuit:
- Electronic expansion valve. The valve enables high system performance and efficiency thanks to a precise response to temperature and pressure variations.
- Liquid and humidity indicator.
- Filter drier and deacidifier on the liquid line.
- Pressure transducers with indication, control and protection function on the high and low pressure lines.
- Safety pressure switch with manual reset on the high pressure line.
- Liquid receiver
- Safety valve on liquid receiver
- Copper refrigerant pipes with anti-condensation insulation on suction line.
- R410A refrigerant charge and lubricating oil.





## ELECTRICAL PANEL

In accordance with EN60204-1, suitable for indoor installation, complete with

- General lock-door disconnecter on front panel;
- Magnetothermal protection switches for compressors and fans.
- Remote control switches for compressor ON/OFF, heating elements and humidifier (when optional). BLDC inverter compressors and treatment fans with EC electric motor do not have contactors.
- Transformer for powering auxiliary circuits and microprocessor.
- Numbered electrical cables.
- Terminal block for:

### OUTPUTS

- Voltage-free deviation contact for general alarm 1,2.
- Voltage-free contact for fan system status signalling.
- Voltage-free contact smoke/fire sensor (sensors are accessory)

### INPUTS

- Remote enabling.
- Supply voltage: 400/3/50.

## CONTROL SYSTEM

- Microprocessor for monitoring the operating states of the unit.
- The system includes:
- Integrated clock for displaying/storing date and time of alarms;
- Internal memory for recording events that have occurred;
- Provision for housing additional connectivity board: MODBUS, LON, BACNET MS/TP RS485, BACNET OVER IP. Electronic boards are accessory;
- Main component operating hours counter;
- Flash" memory for data storage in the event of power failure;
- Menu-driven management with password protection;
- Demand Limit function (only for units with double refrigerant circuit);
- LAN connection (max 15 units).

## DRY-COOLER



Dry-cooler coil with copper tubes and aluminium fins coil:

- with AC axial fan and standard acoustic enclosure **MEDR-TF-A**
- with AC axial fan and low-noise acoustic enclosure **MEDR-TF-SL-A**
- with EC axial fan and standard acoustic enclosure **MEDR-TF-E**
- with EC axial fan and low-noise acoustic enclosure **MEDR-TF-SL-E**

## STANDARD EQUIPMENT



### ELECTRONIC EXPANSION VALVE

The electronic expansion valve serves to precisely control overheating under various environmental conditions and is regulated by the controller.



### 6192 – COMPACT KEYBOARD

The unit is equipped with the controller connected to a 6-button keyboard and graphic display on which all information is displayed in English or with easily identifiable symbols.



### A491 – FLOOD SENSOR

The system includes an electronic relay installed in the electrical panel of the machine and a water detector.

The electrical connections for the probe and the alarm contact are present in the machine's terminal board.

Sensor is supplied to be connected and installed at customer care.

### B670 – UPPER PROTECTION GRILLE

In the OVER units the top protective grille is provided, it is possible to request that the grille be removed (combination with plenum/ducting)



### A181 – COMPRESSOR SOUNDPROOF JACKET

The system includes a soundproof jacket for each compressor to obtain a reduction of the sound level of the unit.



### A501 – CLOGGED FILTER SENSOR

The system includes a differential pressure switch installed in the electrical panel or in the front of the indoor unit and the plastic hoses for the relief of the pressure upstream and downstream the air filters.

Control range: 0.3 ... 4.0 mbar (30 ... 400 Pa)

Differential for intervention: 0.15 mbar (15 Pa)



### **B804 2 WAY VALVE 0/10V (DX DF VERSION)**

The water flow control in the finned coil is carried out by a 2-way modulating ball valve of the equipercentage type with characterisation disc



# TECHNICAL DATA

x-AV3 DW / DW DF / DW FC

Data Book  
DB\_CV\_x-AV3-i-G02-DW\_102022\_EN\_rev00

## TECHNICAL DATA - UNDER / OVER version

Air supply (1)		U / O	U / O	U / O	U / O	U / O
<b>MODEL</b>		<b>029</b>	<b>040</b>	<b>051</b>	<b>052</b>	<b>067</b>
<b>FRAME</b>		<b>M</b>	<b>M</b>	<b>M</b>	<b>L</b>	<b>L</b>
<b>COOLING CAPACITY (2)</b>		<b>100%</b>	<b>100%</b>	<b>100%</b>	<b>100%</b>	<b>100%</b>
Total	[kW]	30,5	42,1	53,3	54,8	70,1
Sensible	[kW]	30,5	42,1	53,3	54,8	70,1
SHR (3)		1,00	1,00	1,00	1,00	1,00
Total power input (Comp. + Fans.)	[kW]	6,38	9,61	14,2	11,8	16,4
Condenser water flow rate	[m <sup>3</sup> /h]	6,26	8,67	11,37	11,16	14,43
Condenser pressure drop	[kPa]	19,3	34,6	55,8	51,1	32,6
<b>"EC" SUPPLY FANS</b>	[n]	<b>1</b>	<b>1</b>	<b>1</b>	<b>2</b>	<b>2</b>
Air flow	[m <sup>3</sup> /h]	8000	10500	11000	14750	17000
Nominal external static pressure	[Pa]	20	20	20	20	20
Power input (4)	[kW]	0,8	1,63	1,92	2,15	3,23
<b>COMPRESSOR</b>		Scroll	Scroll	Scroll	Scroll	Scroll
BLDC compressor	[kW]	1	1	1	1	1
ON/OFF compressor	[Pa]	0	0	0	0	1
Cooling capacity control		Modulating	Modulating	Modulating	Modulating	Modulating
Compressor power input	[kW]	5,58	7,98	12,3	9,68	13,2
<b>AIR FILTERS</b>	[n]	<b>2</b>	<b>2</b>	<b>2</b>	<b>3</b>	<b>3</b>
Efficiency (ISO EN 16890)	COARSE	60%	60%	60%	60%	60%
<b>GAS circuits</b>	[n]	<b>1</b>	<b>1</b>	<b>1</b>	<b>1</b>	<b>1</b>
<b>POWER SUPPLY</b>	V/Ph/Hz	400/3/50	400/3/50	400/3/50	400/3/50	400/3/50
<b>ENERGY EFFICIENCY INDEX (2)</b>						
EER - Energy Efficiency Ratio (5)	[kW/kW]	4,78	4,38	3,75	4,64	4,27
<b>DIMENSIONS</b>						
Length	[mm]	1142	1142	1142	1930	1930
Width	[mm]	885	885	885	885	885
Height	[mm]	1980	1980	1980	1980	1980
<b>NET WEIGHT Over</b>	[kg]	<b>378</b>	<b>384</b>	<b>385</b>	<b>485</b>	<b>525</b>
<b>NET WEIGHT Under</b>	[kg]	<b>387</b>	<b>393</b>	<b>394</b>	<b>503</b>	<b>544</b>
<b>CONNECTIONS ISO 228/1-G</b>						
Inlet/Outlet Water condenser	[M Ø]	1 1/2"	1 1/2"	1 1/2"	2"	2"
<b>HYDRAULIC CONNECTIONS</b>						
<b>CONDENSATE DISCHARGE</b>						
Rubber pipe – internal diameter	[mm Ø]	19	19	19	19	19

### THE COOLING CAPACITY DOES NOT CONSIDER THE SUPPLY FAN MOTOR THERMAL LOAD

1. U = Under, Downflow / O = Over, Upflow
2. Gross value. Parameters referred to entering air at 30°C - 35% RH; condensing temperature 45°C; ESP=20Pa.
3. SHR = Sensible cooling capacity / Total cooling capacity
4. Corresponding to the nominal external static pressure.
5. The Energy Efficiency Index does not consider the remote air-cooled condenser.

The units highlighted in this publication contain <HFC R410A [GWP100 2088]> fluorinated greenhouse gas.

#### NOTE:

**Below 30% of cooling capacity, the inverter compressor enters the "cycling" area in which the compressor operates with ON / OFF cycles below the minimum modulation frequency (operation only for short periods).**

**SELECT THE UNIT IN THE MODULATION FIELD.**

# TECHNICAL DATA

x-AV3 DW / DW DF / DW FC

Data Book  
DB\_CV\_x-AV3-i-G02-DW\_102022\_EN\_rev00

Air supply (1)		U / O	U / O	U / O	U / O	U / O
<b>MODEL</b>		<b>076</b>	<b>078</b>	<b>090</b>	<b>108</b>	<b>140</b>
<b>FRAME</b>		<b>L</b>	<b>XL</b>	<b>XL</b>	<b>XL</b>	<b>XL</b>
<b>COOLING CAPACITY (2)</b>		<b>100%</b>	<b>100%</b>	<b>100%</b>	<b>100%</b>	<b>100%</b>
Total	[kW]	79,3	82,2	94,7	113	146
Sensible	[kW]	79,3	82,2	94,7	113	146
<b>SHR (3)</b>		<b>1,00</b>	<b>1,00</b>	<b>1,00</b>	<b>1,00</b>	<b>1,00</b>
Total power input (Comp. + Fans.)	[kW]	19,7	17,4	21,6	26,4	39,6
Condenser water flow rate	[m3/h]	16,69	16,70	19,51	23,22	31,03
Condenser pressure drop	[kPa]	42,1	36,7	48,1	26,2	44,4
<b>"EC" SUPPLY FANS</b>		<b>2</b>	<b>2</b>	<b>2</b>	<b>3</b>	<b>3</b>
Air flow	[m3/h]	17000	21500	22500	25500	27000
Nominal external static pressure	[Pa]	20	20	20	20	20
Power input (4)	[kW]	3,23	3,24	3,67	5,19	6,28
<b>COMPRESSOR</b>		<b>Scroll</b>	<b>Scroll</b>	<b>Scroll</b>	<b>Scroll</b>	<b>Scroll</b>
BLDC compressor	[n]	1	2	2	2	2
ON/OFF compressor	[n]	1	0	0	2	2
Cooling capacity control		Modulating	Modulating	Modulating	Modulating	Modulating
Compressor power input	[kW]	16,5	14,2	17,9	21,2	33,3
<b>AIR FILTERS</b>		<b>3</b>	<b>4</b>	<b>4</b>	<b>4</b>	<b>4</b>
Efficiency (ISO EN 16890)	COARSE	60%	60%	60%	60%	60%
<b>GAS circuits</b>		<b>1</b>	<b>2</b>	<b>2</b>	<b>2</b>	<b>2</b>
<b>POWER SUPPLY</b>	V/Ph/Hz	<b>400/3/50</b>	<b>400/3/50</b>	<b>400/3/50</b>	<b>400/3/50</b>	<b>400/3/50</b>
<b>ENERGY EFFICIENCY INDEX (2)</b>						
EER - Energy Efficiency Ratio (5)	[kW/kW]	4,03	4,72	4,38	4,28	3,69
<b>DIMENSIONS</b>						
Length	[mm]	1930	2880	2880	2880	2880
Width	[mm]	885	885	885	885	885
Height	[mm]	1980	1980	1980	1980	1980
<b>NET WEIGHT Over</b>	[kg]	<b>526</b>	<b>936</b>	<b>937</b>	<b>1061</b>	<b>1063</b>
<b>NET WEIGHT Under</b>	[kg]	<b>545</b>	<b>976</b>	<b>977</b>	<b>1101</b>	<b>1103</b>
<b>CONNECTIONS ISO 228/1-G</b>						
Inlet/Outlet Water condenser	[M Ø]	2"	2 1/2"	2 1/2"	2 1/2"	2 1/2"
<b>HYDRAULIC CONNECTIONS</b>						
<b>CONDENSATE DISCHARGE</b>						
Rubber pipe – Internal diameter	[mm Ø]	19	19	19	19	19

## THE COOLING CAPACITY DOES NOT CONSIDER THE SUPPLY FAN MOTOR THERMAL LOAD

1. U = Under, Downflop / O = Over, Upflow
2. Gross value. Parameters referred to entering air at 30°C - 35% RH; condensing temperature 45°C; ESP=20Pa.
3. SHR = Sensible cooling capacity / Total cooling capacity
4. Corresponding to the nominal external static pressure.
5. The Energy Efficiency Index does not consider the remote air-cooled condenser.

The units highlighted in this publication contain <HFC R410A [GWP100 2088]> fluorinated greenhouse gas.

### NOTE:

**Below 30% of cooling capacity, the inverter compressor enters the "cycling" area in which the compressor operates with ON / OFF cycles below the minimum modulation frequency (operation only for short periods).**

**SELECT THE UNIT IN THE MODULATION FIELD**

## REFRIGERANT CHARGE

The air conditioner is supplied with a minimum R410A refrigerant charge. **Refrigerant must be charged.** The following table shows the refrigerant charge that must be introduced for the air conditioner only. Remote condenser, connections pipes and optional are excluded.

Air supply (1)		U / O	U / O	U / O	U / O	U / O
MODEL		29	40	51	52	67
FRAME		M	M	M	L	L
REFRIGERANT		R410A	R410A	R410A	R410A	R410A
Gas circuits x Refrigerant charge (2)	n x kg	1 x 6,2	1 x 7,3	1 x 7,4	1 x 8,4	1 x 10,3
HFC R410A - F Gas - CO <sub>2</sub> equivalent	t	12,9	15,2	15,4	17,5	21,5

Air supply (1)		U / O	U / O	U / O	U	U
MODEL		76	78	90	108	140
FRAME		L	XL	XL	XL	XL
REFRIGERANT		R410A	R410A	R410A	R410A	R410A
Gas circuits x Refrigerant charge (2)	n x kg	1 x 10,4	2 x 9,4	2 x 9,5	2 x 12	2 x 12,1
HFC R410A - F Gas - CO <sub>2</sub> equivalent	t	21,7	39,2	39,7	50,1	50,5

1. U = Under, downflow / O = Over, upflow

2. Refrigerant charge required for the air conditioner only operation. Remote condenser, connections pipes and optional are excluded.

For air conditioners with double refrigerant circuit is indicated the number of circuits x the charge of a single circuit.

## DUAL FLUID SYSTEM

The DUAL FLUID system allows for a system with two separate cooling sources:

- Chilled water battery;
- Direct expansion coil;



The microprocessor control automatically manages the system, activating the most convenient cooling circuit according to the set parameters. This system allows many system problems to be solved simply and in a small space, including:

- System supplied with well water in reserve to the main cooling circuit.
- Dual supply system with two independent sources. This solution is used when redundancy of the cooling system must be guaranteed.

Temperature control is carried out with the same logic as the main coil.

## FREE-COOLING SYSTEM

The FREE COOLING system allows for a two-source cooling system:

- Free-cooling coil;
- Direct expansion coil.



This system consists of

- Water-cooling coil
- 2-way regulating valve for water flow control on free-cooling coil
- 2-way regulating valve for condensation control on water condenser
- Outside air temperature probe

The cooling coil is positioned in the return air flow downstream of the filter section. In this way the air is partially or totally cooled before passing through the main cooling coil.

### OPERATING LOGIC

The integration of the FREE-COOLING system with the water circuit of the DW machines and the connection to an external heat sink (MEDR-TF) makes it possible to create a free-cooling circuit with the operating characteristics described below. With external temperatures of 5°C or less, the FREE-COOLING system provides the total capacity of the system without requiring the operation of the compressors (total free cooling).

With external temperatures between 5°C and 21°C, the FREE-COOLING system provides pre-cooling by activating the compressors only to provide the cooling power necessary to completely balance the load (partial free cooling). The system is managed by the microprocessor control incorporated in the unit.

The probe (Tin) provides the microprocessor control with the temperature of the glycol mixture arriving from the external heat sink (DC) to allow continuous comparison with the return air temperature. When the return air temperature is 2°C higher than the temperature of the glycol mixture, the microprocessor control activates the valve (M1) which modulates the amount of water in the coil (FC) to achieve total or partial free cooling.

In the case of partial free cooling, the compressor(s) are activated to ensure complete balancing of the ambient load. In this case, part of the glycol mixture is diverted by the condensation control valves (VA) into the heat exchangers (CND1) to dissipate the condensation heat.

## TECHNICAL DATA

x-AV3 DW / DW DF / DW FC

Data Book

DB\_CV\_x-AV3-i-G02-DW\_102022\_EN\_rev00

## TECHNICAL DATA CHILLED WATER COIL

AIR SUPPLY (1)		U / O	U / O	U / O	U / O	U / O
MODEL		29	40	51	52	67
FRAME		M	M	M	L	L
<b>COOLING CAPACITY (2)</b>						
Total	kW	36,2	44,5	46,1	62,8	69,6
Sensible	kW	36,2	44,5	46,1	62,8	69,6
SHR (3)		1	1	1	1	1
<b>COOLING COIL</b>						
Water flow (2)	m <sup>3</sup> /h	5,2	6,4	6,62	9,02	9,99
dP coil + valve (2)	kPa	33,5	48,4	51,5	38,5	46,4
Content water	l	9,2	9,2	9,2	12,5	12,5
<b>HYDRAULIC CONNECTIONS</b>						
INLET / OUTLET WATER - ISO 7/1	Ø	1 ½"	1 ½"	1 ½"	2"	2"

AIR SUPPLY (1)		U / O	U / O	U / O	U
MODEL		76	78	90	108
FRAME		L	XL	XL	XL
<b>COOLING CAPACITY (2)</b>					
Total	kW	69,6	96,1	99,2	109
Sensible	kW	69,6	96,1	99,2	109
SHR (3)		1	1	1	1
<b>COOLING COIL</b>					
Water flow (2)	m <sup>3</sup> /h	9,99	13,8	14,2	15,6
dP coil + valve (2)	kPa	46,4	49	51,9	61,2
Content water	l	12,5	20,3	20,3	20,3
<b>HYDRAULIC CONNECTIONS</b>					
INLET / OUTLET WATER - ISO 7/1	Ø	2"	2 ½"	2 ½"	2 ½"

### THE COOLING CAPACITY DOES NOT TAKE THE THERMAL LOAD OF THE FAN INTO ACCOUNT

1. U = Under, Downflow / O = Over, Upflow
2. Gross value. Parameters referred to entering air at 30°C-35%UR and chilled water 10-16°C - 0% glicole
3. SHR = Sensible cooling capacity / Total cooling capacity

## 2-WAY BALL VALVE FOR CHILLED WATER FLOW CONTROL (Dual Fluid version)



The water flow control in the finned coil is achieved through a **2-way modulating ball valve with equal percentage flow control** ensured by the integrated characterizing disc.

This type of valve offers the following series of benefits:

- Equal percentage flow control.
- No peaks initial flow.
- Excellent stability control thanks to the integrated characterizing disc.
- Excellent characteristic in partialisation.
- Stability in control.
- Maintenance free.
- Self-cleaning.

### CHARACTERISTICS OF THE 2-WAY BALL VALVE

- Closing seal with leakage rate in Class A (EN 12266-1)
- Maximum fluid pressure  $P_s=1600\text{kPa}$
- Maximum closing pressure (Close-off)  $\Delta P_s=1400\text{kPa}$

The rotative actuator is controlled by a signal 0 ... 10VDC from the microprocessor controller. The actuator is equipped with an emergency button for manual operation and is maintenance-free.

Model		29	40	51	52	67	76	78	90	108
Frame		M	M	M	L	L	L	XL	XL	XL
<b>2 way valve</b>										
kv	[m3/h]	16	16	16	25	25	25	40	40	40

## WATER QUALITY OF THE HYDRAULIC CIRCUITS

The values shown in the table must be guaranteed during the entire life cycle of the machine

	Description	Symbol	Range
1	Hydrogen Ions	pH	7.5 ÷ 9
2	Presence of calcium (Ca) and magnesium (Mg)	Hardness	4 ÷ 8.5 °D
3	Chlorine ions	Cl <sup>-</sup>	< 150 ppm
4	Iron Ions	Fe <sup>3+</sup>	< 0.5 ppm
5	Manganese Ions	Mn <sup>2+</sup>	< 0.05 ppm
6	Carbon dioxide	CO <sub>2</sub>	< 10 ppm
7	Hydrogen sulphide	H <sub>2</sub> S	< 50 ppb
8	Oxygen	O <sub>2</sub>	< 0.1 ppm
9	Chlorine	Cl <sub>2</sub>	< 0.5 ppm
10	Ammonia NH <sub>3</sub>	NH <sub>3</sub>	< 0.5 ppm
11	Ratio between carbonates and sulphates	HCO <sub>3</sub> <sup>-</sup> /SO <sub>4</sub> <sup>2-</sup>	> 1
12	Sulphate ions	SO <sub>4</sub> <sup>-</sup>	< 100 ppm
13	Phosphate ions	PO <sub>4</sub> <sup>3-</sup>	< 2.0 ppm

Where:  $1/1.78^\circ\text{D} = 1^\circ\text{Fr}$  con  $1^\circ\text{Fr} = 10 \text{ gr CaCO}_3 / \text{m}^3$

ppm = parts for millions

ppb = parts for billion

**Explanatory notes:**

- ref.1: A greater concentration of hydrogen ions (pH) than 9 implies a high risk of deposits, whereas a lower pH than 7 implies a high risk of corrosion.
- ref.2: The hardness measures the amount of Ca and Mg carbonate dissolved in the water with a temperature lower than 100°C (temporary hardness). A high hardness implies a high risk of deposits.
- ref.3: The concentration of chloride ions with higher values than those indicated causes corrosion.
- ref. 4 - 5 - 8: The presence of iron and manganese ions and oxygen leads to corrosion.
- ref.6 - 7: Carbon dioxide and hydrogen sulphide are impurities that promote corrosion.
- ref.9: Usually in water from the waterworks it is a value of between 0.2 and 0.3 ppm. High values cause corrosion.
- ref.10: The presence of ammonia reinforces the oxidising power of oxygen
- ref.11: Below the value shown in the table, there is a risk of corrosion due to the trigger of galvanic currents between copper and other less noble metals.
- ref.12: The presence of sulphates ions triggers corrosion phenomenon.
- ref.13: The presence of phosphates ions triggers corrosion phenomenon.

It is necessary to carry out periodic checks, with withdrawals at different points of the hydraulic system. During the first year of operation, checks are recommended every 4 months which can be reduced every 6 months starting from the second year of operation.

**WARNING:**

**Values of the parameters outside the indicated ranges can lead to the formation of deposits and limescale and/or favour corrosive phenomena within the plant. For operating fluids other than water (mixtures of ethylene and propylene glycol) it is recommended to use specific inhibitors, designed to offer thermal stability within the operating temperature range and protection against corrosion. It is necessary that, in the presence of dirty and / or aggressive waters, an intermediate heat exchanger is installed upstream of the heat exchangers**

**ANTIFREEZE MIXTURES**

In systems that are not adequately protected by electric heaters, protect the water circuit with anti-freeze mixture when the outside air temperature may fall below 5°C.

		% suggerita in peso									
		%	0	12	20	30	35	40	45	50	
ETHYLENE GLYCOL	Minimum outdoor air temperature	°C	5	0	-5	-10	-15	-20	-25	-30	
PROPYLENE GLYCOL	Minimum outdoor air temperature	°C	5	2	-3	-9	-13	-17	-23	-29	

The values are indicative and may significantly vary depending on the glycol manufacturer. Refer to your glycol supplier for detail.

The values consider a precautionary difference of 5°C between the minimum ambient air temperature and the freezing temperature of the mixture.

In the hydraulic circuit do not send fluids other than water or mixtures with ethylene / propylene glycol.

If other products are provided, in addition to mixtures of water and ethylene or propylene glycol, contact the Manufacturer to check the compatibility with the machine components.



## REFRIGERANT CIRCUIT

Below refrigerant diagrams for version with single or double refrigerant circuit. The diagrams refer to the standard configuration, without optional.

DW / DF DW UNDER - SINGLE REFRIGERANT CIRCUIT

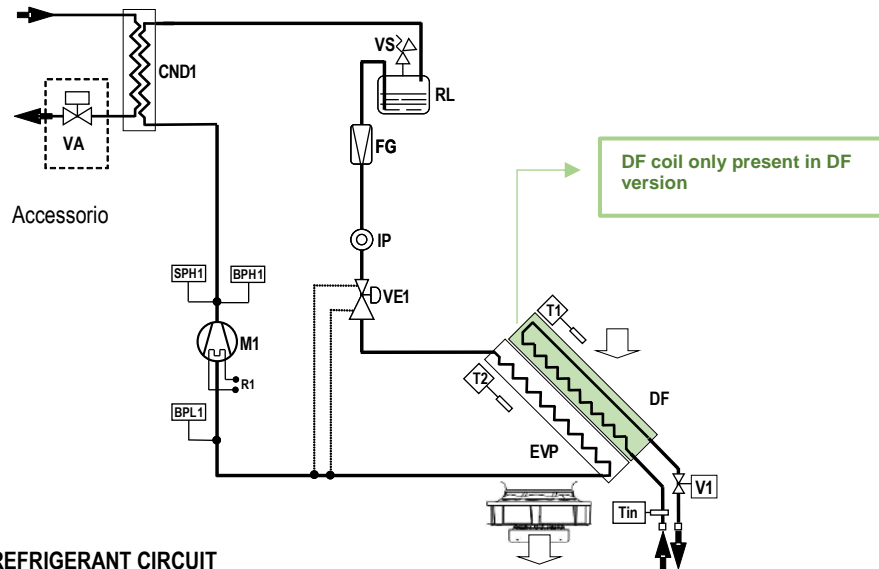

DW / DF DW OVER - SINGLE REFRIGERANT CIRCUIT

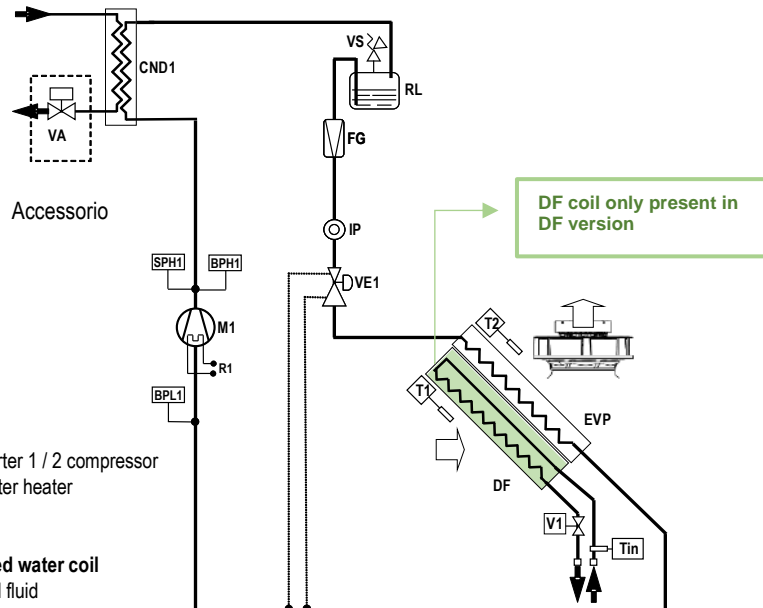

### LEGENDA

- M1 / M2: BLDC inverter 1 / 2 compressor
- R1 : compressor carter heater
- CND: condensator
- EVP: evaporator
- DF: Dual fluid chilled water coil
- V1: 2-way valve dual fluid
- BPH: High pressure transducer
- BPL: Low pressure transducer
- VS: relief valve
- FG: refrigerant gas FILTER
- IP: Passage indicator
- VE: Expansion valve
- T: temperature probe
- RL: liquid receiver
- VA: Motorized valve for condensation control
- SPH: high-pressure switch-

## DW / DW DF UNDER – DOUBLE REFRIGERANT CIRCUIT

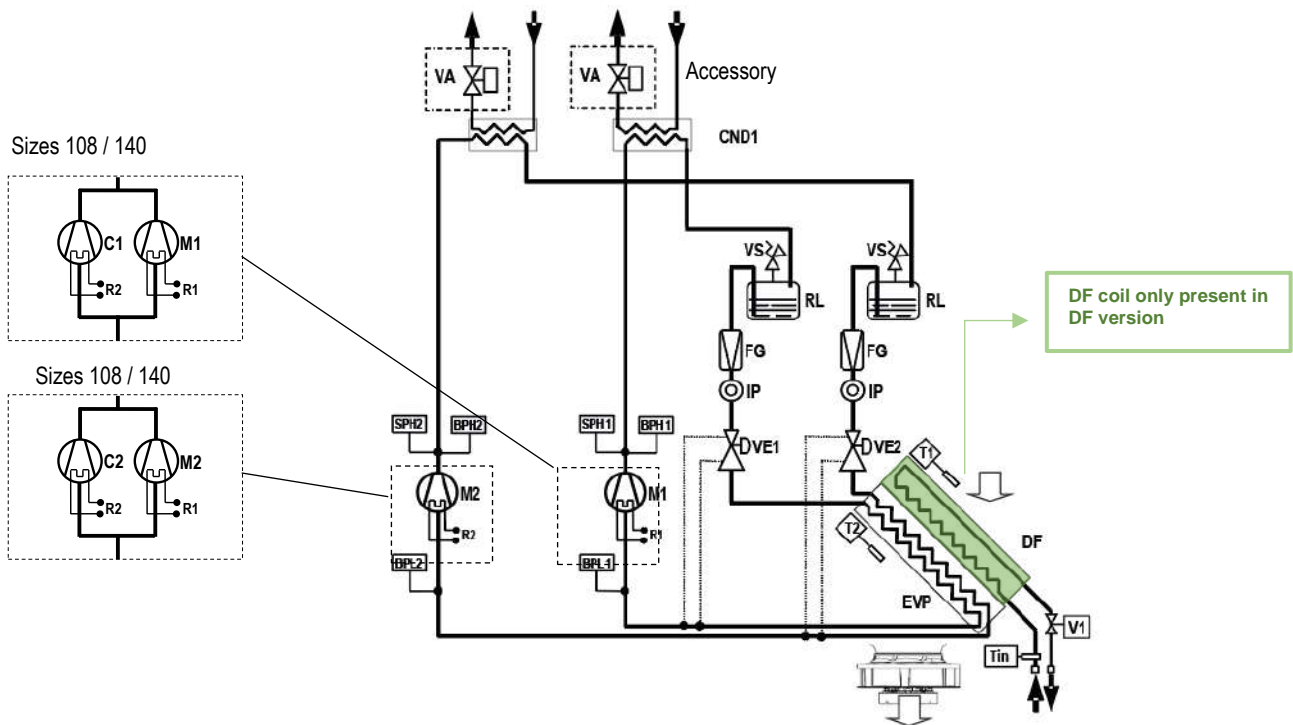

## DW / DW DF UNDER – DOUBLE REFRIGERANT CIRCUIT

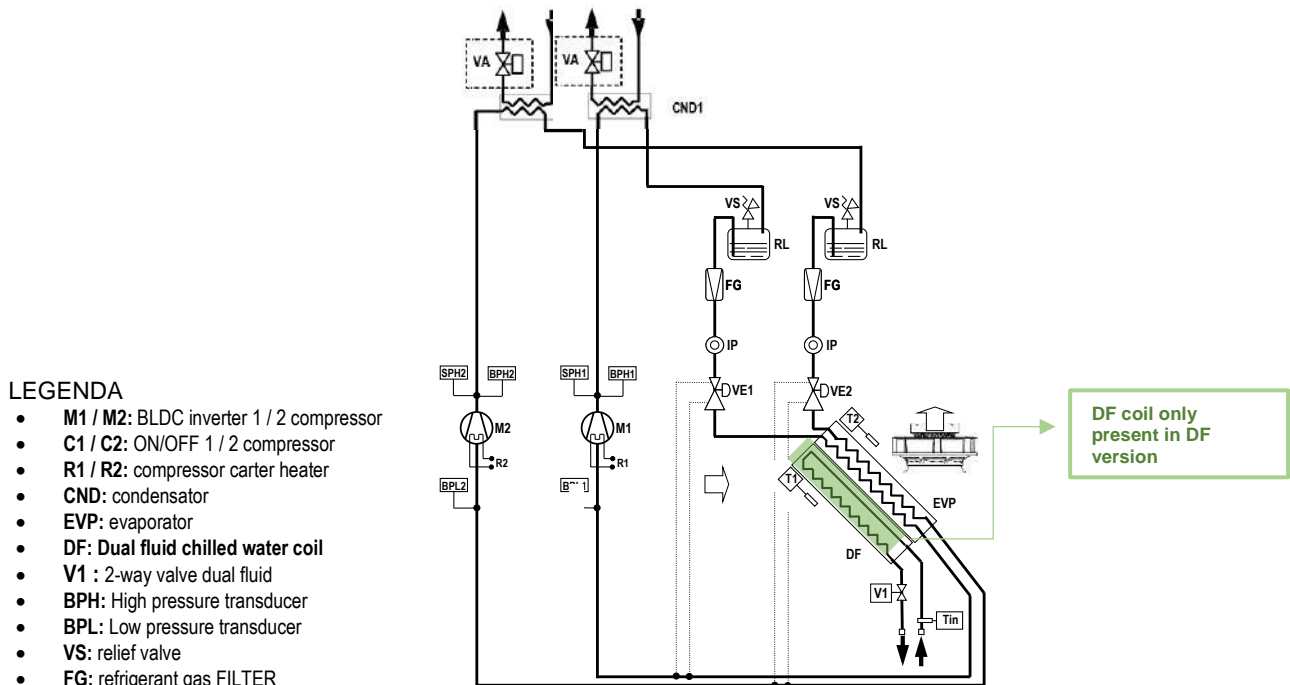

### LEGENDA

- M1 / M2: BLDC inverter 1 / 2 compressor
- C1 / C2: ON/OFF 1 / 2 compressor
- R1 / R2: compressor carter heater
- CND: condensator
- EVP: evaporator
- DF: Dual fluid chilled water coil
- V1 : 2-way valve dual fluid
- BPH: High pressure transducer
- BPL: Low pressure transducer
- VS: relief valve
- FG: refrigerant gas FILTER
- IP: Passage indicator
- VE: Expansion valve
- T: temperature probe
- RL: liquid receiver
- VA: Motorized valve for condensation control
- SPH: high-pressure switch

## DW FC - REFRIGERATION DIAGRAM

Below are the refrigeration diagrams of the single- and dual-circuit versions. The diagrams refer to the standard configuration, without accessories.

### DW FC UNDER - SINGLE REFRIGERANT CIRCUIT

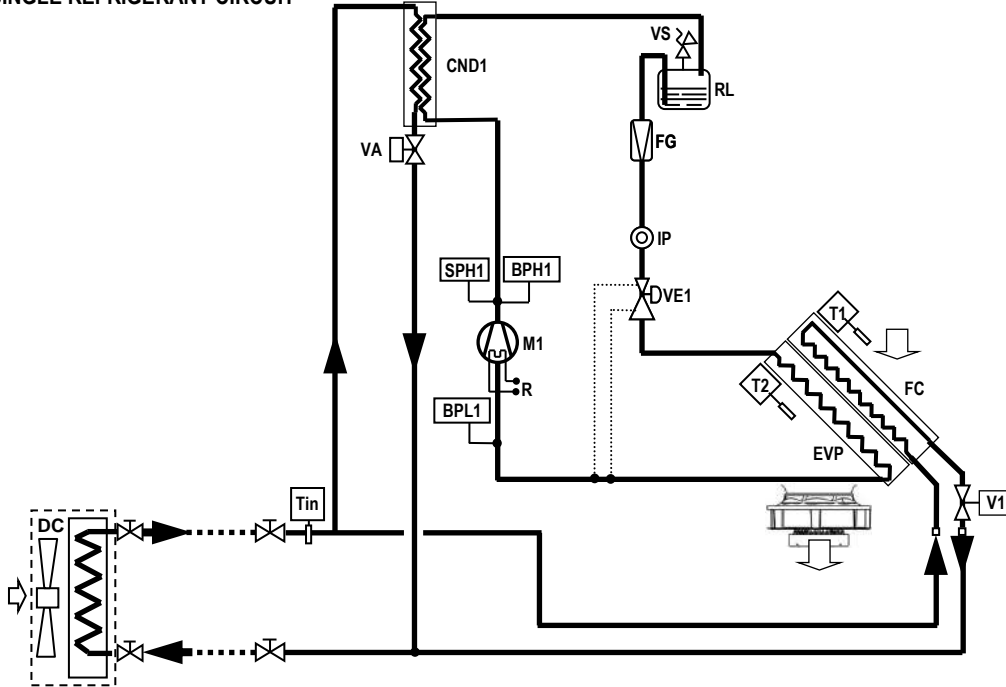

### DW FC OVER - SINGLE REFRIGERANT CIRCUIT

#### LEGENDA

- M1: BLDC inverter 1 / 2 compressor
- R1: compressor carter heater
- CND: condensator
- EVP: evaporator
- FC: Free-cooling coil
- BPH: High pressure transducer
- BPL: Low pressure transducer
- VS: relief valve
- FG: refrigerant gas FILTER
- IP: Passage indicator
- VE: Expsansion valve
- T: temperature probe
- RL: liquid receiver
- VA: Motorized valve for condensation control
- SPH: high-pressure switch
- V1 Free-cooling 2-way valve
- DC: Dry-cooler
- 

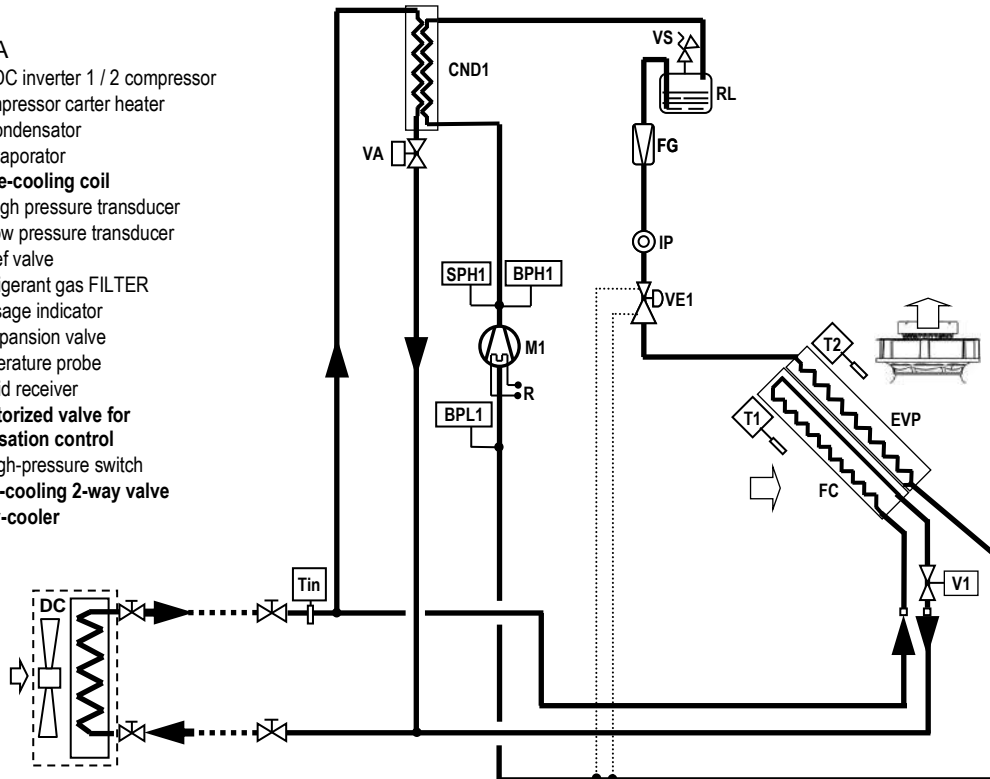

## DW FC - DUAL REFRIGERANT CIRCUIT

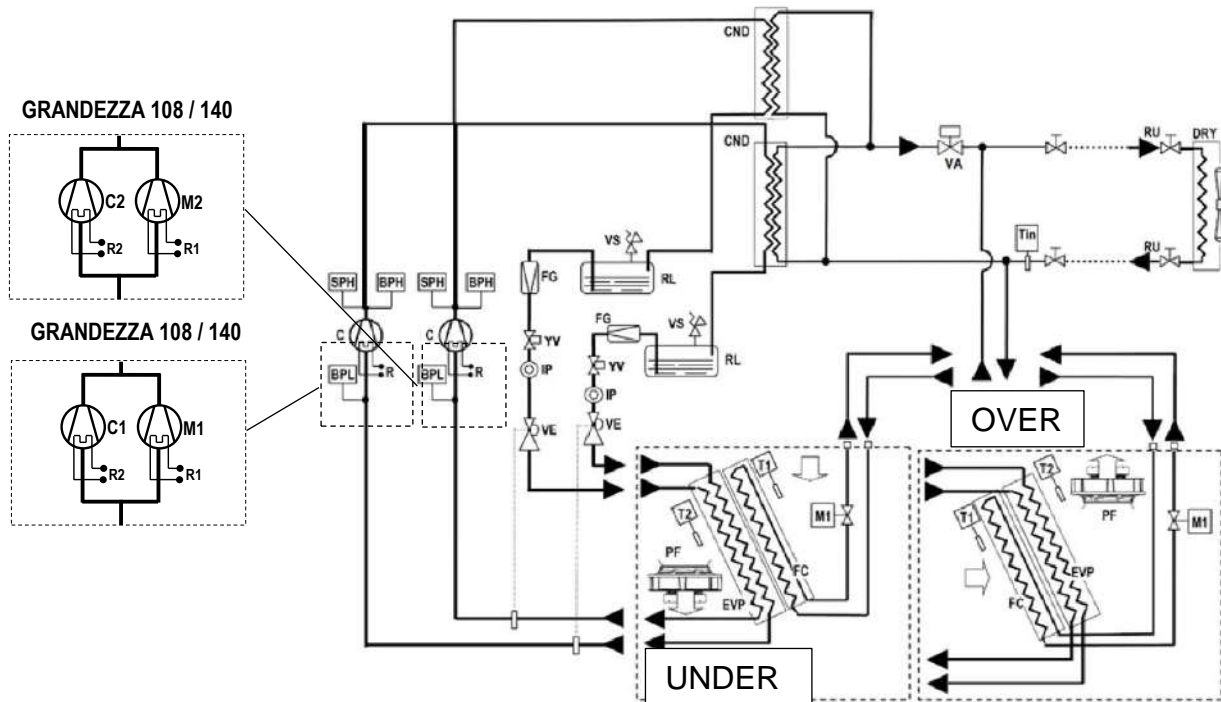

### LEGENDA

- **M1/M2:** BLDC inverter 1 / 2 compressor
- **C1/C2:** ON/OFF 1 / 2 compressor
- **R1/R2:** compressor carter heater
- **CND:** condensator
- **EVP:** evaporator
- **FC: Free-cooling coil**
- **BPH:** High pressure transducer
- **BPL:** Low pressure transducer
- **VS:** relief valve
- **FG:** refrigerant gas FILTER
- **IP:** Passage indicator
- **VE:** Exspansion valve
- **T:** temperature probe
- **RL:** liquid receiver
- **VA: Motorized valve for condensation control**
- **SPH:** high-pressure switch
- **V1 Free-cooling 2-way valve**
- **DC:** Dry-cooler

## PRESSURE RELIEF VALVE

The pressure relief valve of the refrigerant circuit is installed in the machines when required by Directive 2014/68/EU. The valve is installed on liquid receiver and oil separator of each refrigerant circuit of the machine with the purpose to protect the circuit from overpressure.

**It is up to the installer to check whether the system complies with the 2014/68 / EU standard regarding the installation of the pressure relief valve.**

**By plant we mean the complete system that includes the internal machine, the remote condenser and the connecting pipes**

The installer must calculate the amount of refrigerant contained in the system and, if the refrigerant charge is higher than 10 kg, he must install the pressure relief valve.

Model	Pressure relief valve on liquid receiver [bar]
29	41,5
40	41,5
51	41,5
52	41,5
67	41,5
76	41,5
78	41,5
90	41,5
108	41,5
140	41,5

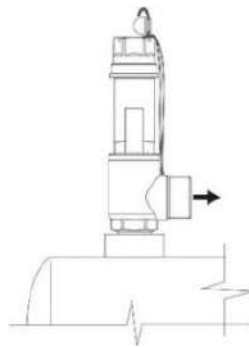

Exhaust flow  
CONNECTION Ø 3/4" G - M

## Acoustic data of the standard machine at full load working conditions.

### WARNING:

In a closed room the noise produced by a sound source reaches the listener in two different ways:

- Directly
- Reflected from the surrounding walls, floor, ceiling, from furniture.

With the same sound source, the noise produced in a closed room is greater than that produced outdoors. In fact, the sound pressure level generated by the source, must be added to the one reflected from the room.

Also, the shape of the room affects the sound.

### Version DW

Model		29	40	51	52	67	76	78	90	108	140
Frame		M	M	M	L	L	L	XL	XL	XL	XL
Cooling capacity		100%	100%	100%	100%	100%	100%	100%	100%	100%	100%
<b>Sound level ISO 3744 (1)</b>											
On supply - Under	dB (A)	63,4	69	70	67,9	70,8	70,8	70,6	71,6	72,3	73,6
On return - Under	dB (A)	64,8	62,9	62,8	62,2	62,9	62,7	64,3	64,3	64,8	64,9
On the front - Under	dB (A)	50,7	47,9	48,1	47,5	48,3	48,2	50,1	50,2	50,5	50,9
On supply - Over	dB (A)	63,4	69	70	67,9	70,8	70,8	70,6	71,6	72,3	73,6
On return - Over (2)	dB (A)	70,1	65,8	64,8	65,8	65,9	65	68,7	67,7	68,8	67,9
On the front - Over (3)	dB (A)	52	48,5	48,5	48,2	48,4	48,3	50,8	50,8	51	51,1

1. Noise pressure level at 1 meter in free field – ISO 3744
2. Air intake from the front
3. Air intake from the bottom

### Version DW DF / DW FC

Model		29	40	51	52	67	76	78	90	108
Frame		M	M	M	L	L	L	XL	XL	XL
Cooling capacity		100%	100%	100%	100%	100%	100%	100%	100%	100%
<b>Sound level ISO 3744 (1)</b>										
On supply - Under	dB (A)	60,2	66,1	67,1	60,8	63,9	63,9	68	69	64,6
On return - Under	dB (A)	60,8	59,4	59,9	58,6	58,8	59,2	60,9	61,4	60,7
On the front - Under	dB (A)	50,6	47,5	47,5	46,8	47,1	47	49,6	49,7	49,4
On supply - Over	dB (A)	60,2	66,1	67,1	60,8	63,9	63,9	68	69	64,6
On return - Over (2)	dB (A)	70	65,7	64,7	65,7	65,8	64,8	68,6	67,6	68,7
On the front - Over (3)	dB (A)	52	48,4	48,3	48,1	48,2	48,1	50,7	50,6	50,8

1. Noise pressure level at 1 meter in free field – ISO 3744
2. Air intake from the front
3. Air intake from the bottom

Electrical data of the system at full load working conditions.

Versione		U/O	U/O	U/O	U/O	U/O	U/O	U/O	U/O	U/O	U/O
Modello		29	40	51	52	67	76	78	90	108	140
Grandezza		M	M	M	L	L	L	XL	XL	XL	XL
Alimentazione elettrica	V/ph/Hz	400/3/50	400/3/50	400/3/50	400/3/50	400/3/50	400/3/50	400/3/50	400/3/50	400/3/50	400/3/50
Massima corrente assorbita (FLA)	A	31,6	41,5	41,5	47	57,4	57,4	82	82	108	108

1. U = Under, Downflov / O = Over, Upflow

**WARNING:**

The electric data indicated refer only to the indoor unit.

Optional accessory electric data are included within the dedicated chapters and must be added.

Please refer to ELCA WORLD selection program to calculate the electrical data of the air conditioner according to the requested optional accessories.

The remote air-cooled condenser is not included because it has independent power supply.



Controller

The unit is equipped with the controller connected to a 6 keys keyboard with graphic display on which all information in English language or easily identifiable symbols are displayed.

The controller disposes of a "flash" memory that preserves the information even in absence of power supply. Part of memory is dedicated to the registration of intervened events - up to 200 events.

The system can manage up to 4 T/H probes on air intake, 4 T/H probes on air delivery, 4 remote T/H probes and a T/H probe for outdoor air. The unit is equipped with the controller connected to a 6 keys keyboard with graphic display on which all information in English language or easily identifiable symbols are displayed.

The controller disposes of a "flash" memory that preserves the information even in absence of power supply. Part of memory is dedicated to the registration of intervened events - up to 200 events.

The system can manage up to 4 T/H probes on air intake, 4 T/H probes on air delivery, 4 remote T/H probes and a T/H probe for outdoor air.

## DISPLAY – KEYBOARD FUNCTIONS



Keyboard and Display

	ALARM	Alarm presence with red light. Push for alarm description. In case of more alarms scroll by UP / DOWN.
	PRG	Menu list, scrolled by UP/DOWN: <b>Unit; Set-point; In/Out; Clock; History; User; Service; Factory.</b> ENTER to execute.
	ESC	Home. Used to come back to the previous menu level or to the main screen.
	UP DOWN	Changes pages and values of sets. By pressing in HOME mask, the synoptic of the main controls is displayed.
	ENTER	Moving the cursor on adjustable Program(s) fields to confirm the changes. Press ENTER to get out the fields.

## DISPLAY – MAIN MASK

area 11	area 1	area 12	HH : MM	DD / MM / YY
	area 2		- 99 . 9 °C	
	area 3		- 99 . 9 %	
	area 3_A			area 8
area 4	area 5	area 6	area 7	area 9
				area 10



Touch 7" Display  
(accessory)

The main mask shows time, date, room temperature and humidity values (if the relative probe is present) and areas for displaying operating and alarm status with dedicated icons

- Area 1: Status of the unit: on / off
- Area 2: Status detail
- Area 3: Type of event (only in case of an event)
- Area 3\_A: Code and type of event
- Area 4: Active cooling devices
- Area 5: Active free-cooling devices
- Area 6: Active humidity devices
- Area 7: Active heating devices
- Area 8: on / off parameters
- Area 9: BMS address
- Area 10: LAN address
- Area 11: Schematic representation of units
- Area 12: Active function presence icon



## CONNECTIVITY

Through the optional serial port, the microprocessor control enables communication with the modern buildings BMS systems with the following protocols: MODBUS; LON; BACNET MS/TP RS485; BACNET OVER IP.

## PASSWORD

Level 1: On request of the End User. Allowing to reach USER menu

Level 2: Asks to Service: Allowing to reach SERVICE menu

Level 3: Asks to Service: Allowing to reach FACTORY menu

No passwords request to enter: UNIT, SETPOINT, IN/OUT, CLOCK, HISTORY menu

## GENERAL SCHEME

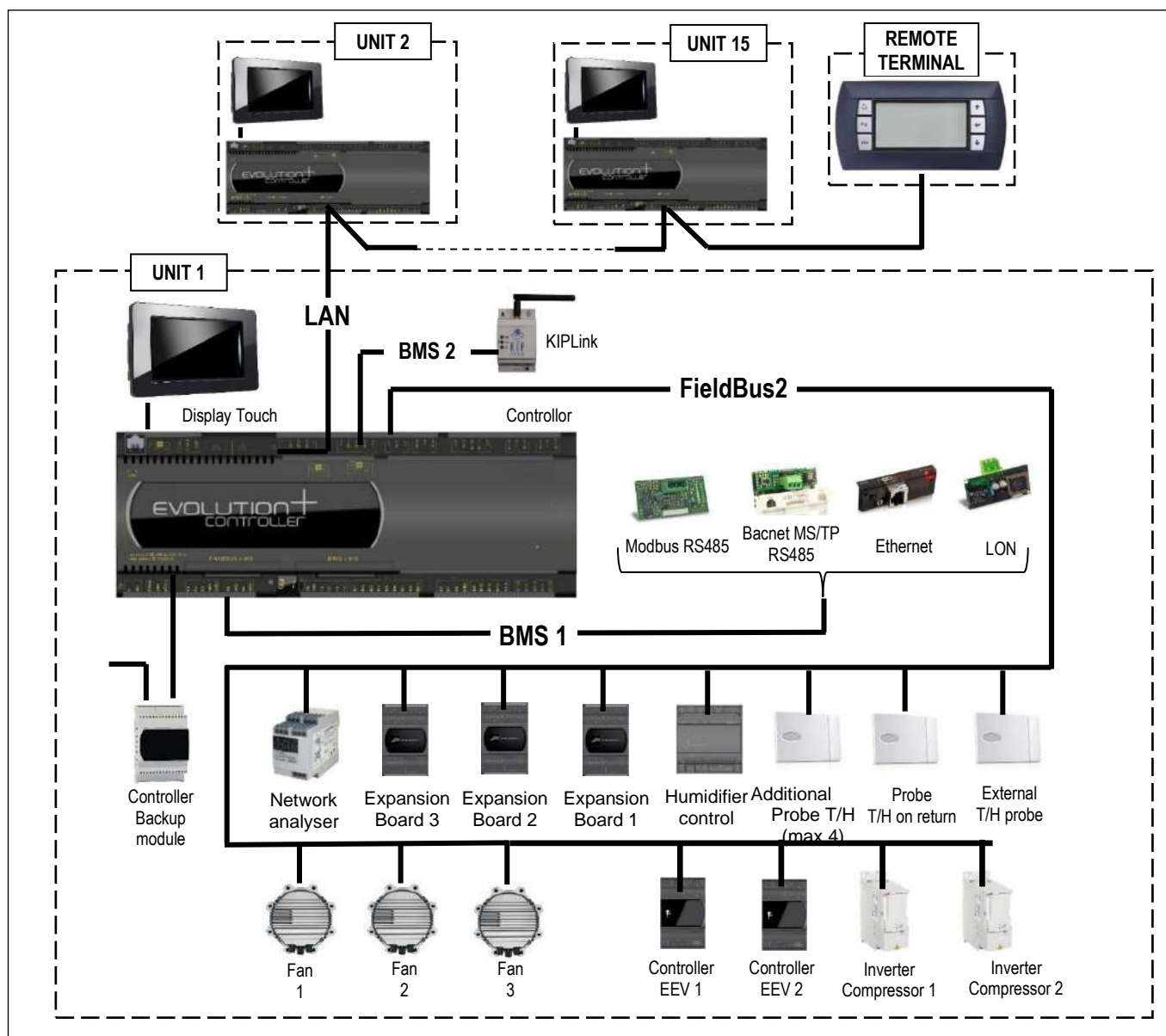

## LAN NETWORK

The LAN is part of the control software and it is possible to connect up to 15 units. This type of connection allows to control the units in coherent way, moreover the units can be controlled and managed from a shared remote terminal.

## LAN ADDRESS LIST

Unit n.	1	2	3	4	5	6	7	8	9	10	11	12	13	14	15	Remote Terminal
Adress Controllor	1	2	3	4	5	6	7	8	9	10	11	12	13	14	15	---
Display & Keyboard adress	16	17	18	19	20	21	22	23	24	25	26	27	28	29	30	32

The unit connection to the local network (LAN) allows to perform the following functions:

- Balancing the operating hours among the different units by rotating the reserve units.
- Turning on the reserve units in case other units should turn off due to an alarm, maintenance or power feed interruption.
- Turning on reserve units to offset the excessive thermal load.
- Operating with all units based on the average temperature and humidity values read by the temperature probes only in the operating units.
- DYNAMIC MASTER function that makes the role of the Master unit dynamic. In case of alarm, shutdown, maintenance, power failure, etc. on the Master unit, the function automatically elects a new Master unit.

## UNIT FIXING BRACKET

The bracket is supplied as an assembly kit, with bolts for fixing it to the unit. It is a safety device that must be installed together with the unit and fixed to a structural part at the installation site (wall, structure, etc.) to avoid the risk of the unit toppling over due to external causes (accidental impacts, earthquakes, etc.). Wall fixing screws are not supplied.

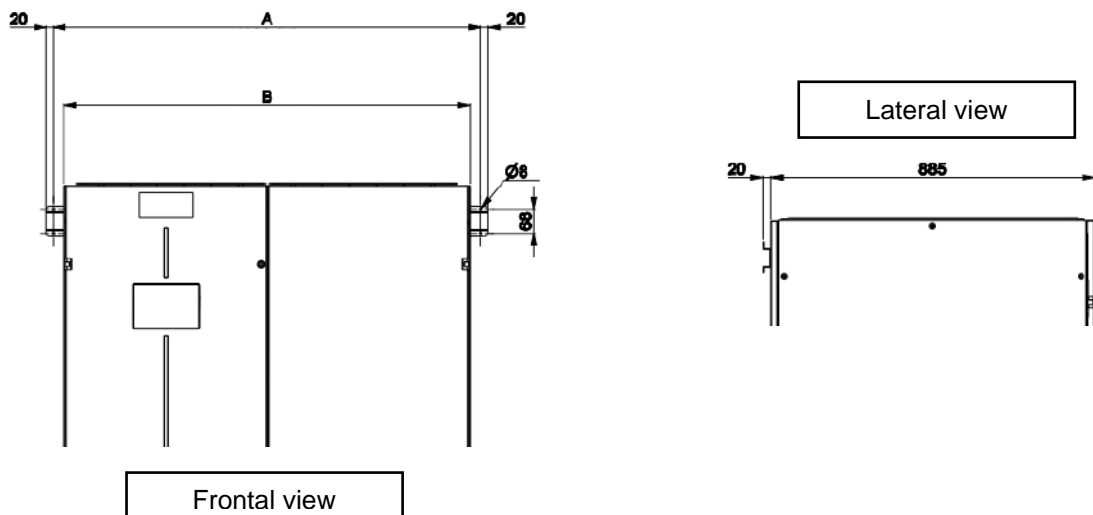

Frame		M	L	XL
Dimension A	mm	1202	1990	2940
Dimension B	mm	1142	1930	2880

B263.....	<b>OVER AIR DELIVERY – BOTTOM INTAKE</b>
B266.....	<b>FRONT. AIR DELIVERY – TOP INTAKE</b>
B681.....	<b>CLOSING BASEMENT. CLOSING PANEL FOR ACOUSTIC INSULATION OF UNIT BASE IN OVER VERSION.</b>
B670.....	<b>WITHOUT UPPER PROTECTION GRILLE</b>
601.....	<b>LIQUID LINE SOLENOID VALVE</b>
A547.....	<b>COSTANT AIR FLOW. AUTOMATIC AISLE AIR FLOW REGULATION SYSTEM. THE SYSTEM CONTROLS THE ROTATION SPEED OF THE FANS SO THAT THE AIR FLOW RATE IS KEPT CONSTANT BY MEANS OF A DIFFERENTIAL PRESSURE TRANSMITTER CONNECTED TO THE MICROPROCESSOR CONTROL.</b>
A548.....	<b>COSTANT PREVALENCE. AUTOMATIC AISLE AIR PRESSURE REGULATION SYSTEM. THE SYSTEM CONTROLS THE ROTATION SPEED OF THE FANS TO KEEP THE AIR PRESSURE CONSTANT VIA A DIFFERENTIAL PRESSURE TRANSMITTER CONNECTED TO THE MICROPROCESSOR CONTROL.</b>
383 .....	<b>NUMBERED WIRINGS + UK REQUESTS</b>
P181 .....	<b>NETWORK ANALYZER (STANDARD MACHINE) MULTIFUNCTION TOOL FOR CALCULATING AND DISPLAYING ELECTRICAL MEASUREMENTS OF THE MACHINE</b>
P111 / P113 .....	<b>DUAL POWER SUPPLY. DUAL POWER SUPPLY SYSTEM WITH AUTOMATIC CHANGE-OVER.</b>
	<b>P111 – DUAL POWER SUPPLY</b>
	<b>P113 - DUAL POWER SUPPLY KIT. SUPPLIED IN KIT</b>
4181 / 4182 / 4184 / 4185	<b>SERIAL CARDS:</b>
	<b>4181 – SERIAL CARD MODBUS;</b>
	<b>4182 – SERIAL CARD LON;</b>
	<b>4184 – SERIAL CARD BACNET MS/TP RS485;</b>
	<b>4185 – SERIAL CARD BACNET OVER IP.</b>
6461 .....	<b>HPC.</b>
1441 .....	<b>KIPLINK + COMPACT KEYBOARD</b>
1442 .....	<b>KIPLINK+ TOUCH SCREEN 7’</b>
6195 .....	<b>TOUCH SCREEN 7 ‘</b>
6196 .....	<b>KIPLINK</b>
C9261063 .....	<b>REMOTE DISPLAY</b>
P151.....	<b>LOWERED DISPLAY FOR UNDER – ONLY UNDER MACHINES EQUIPPED WITH PLENUM UNDER THE UNIT.</b>
A492.....	<b>WATER LEAKAGE DETECTOR + ADDITIONAL SENSOR. SUPPLIED IN MOUNTING KIT.</b>
A511.....	<b>SMOKE DETECTOR. SUPPLIED IN MOUNTING KIT..</b>
A521.....	<b>FIRE DETECTOR. SUPPLIED IN MOUNTING KIT..</b>
B811.....	<b>AIR FLOW SENSOR</b>
4503 .....	<b>FAST RESTART (ULTRACAP)</b>
2412 .....	<b>PHASE SEQUENCE CONTROL</b>
A381.....	<b>CONDENSATE DRAIN PUMP. FORNITA IN KIT DI MONTAGGIO. IL KIT COMPRENDE POMPA CON GALLEGGIANTE DI ATTIVAZIONE E 10M LINEARI DI TUBAZIONE PER LO SCARICO.</b>
A812 (2).....	<b>DIRECT FREE-COOLING. MANAGEMENT DIRECT FREE-COOLING.</b>
A791.....	<b>AIR TEMPERATURE CONTROL ON SUCTION AIR..</b>
A431.....	<b>ELECTRIC RESISTENCE. HEATING WITH ELECTRIC RESISTENCE.</b>
B803	<b>VALVE 3 VIE 0/10V</b>
B807	<b>VALVE 2 VIE EPIV</b>
P051 (4) .....	<b>DEUMIDIFICATION FUNCTION.</b>

<b>4303 / 4305 (5)</b> .....	<b>HUMIDIFICATION: MODULATING STEAM HUMIDIFIER WITH IMMERSSED ELECTRODES AND ELECTRONIC CONTROL.</b> <b>4303 - HUMIDIFIER VAP. 8KG/H</b> <b>4305 - HUMIDIFIER VAP. 15KG/H</b>
<b>P161</b> .....	<b>AIR SUCTION PROBE T/RH. COMBINED TEMPERATURE / HUMIDITY PROBE ON AIR INTAKE. THE ACCESSORY REPLACES THE TEMPERATURE PROBE INSTALLED ON THE AIR INTAKE IN THE INDOOR UNIT.</b>
<b>P071/P072/P073/P074</b>	<b>SONDA T/RH REMOTA. COMBINED TEMPERATURE / AMBIENT HUMIDITY PROBE. FOR REMOTE INSTALLATION, IN ADDITION TO THE COMBINED PROBE ON THE MACHINE AIR INTAKE.</b>
<b>P101</b> .....	<b>EARTHQUAKE ANCHOR KIT</b>
<b>P084</b> .....	<b>AIR FILTER EPM10 50%. HIGHLY EFFICIENT REGENERABLE AIR FILTER (SECONDO ISO EN 16890).</b>
<b>B961-B971</b> .....	<b>PLENUM EMPTY</b>
<b>B962-B972</b> .....	<b>PLENUM EMPTY + INSULATION</b>
<b>B963-B973</b> .....	<b>PLENUM EMPTY + DAMPER</b>
<b>B964-B974</b> .....	<b>PLENUM EMPTY INSULATION+DAMPER</b>
<b>B965-B975</b> .....	<b>PLENUM 1 GRILLE</b>
<b>B966-B976</b> .....	<b>PLENUM 1 GRILLE INSULATION</b>
<b>B967-B977</b> .....	<b>PLENUM 1 GRILLE + DAMPER</b>
<b>B968-B978</b> .....	<b>PLENUM 1 GRILLE INSULATION +DAMPER</b>
<b>B969-B979</b> .....	<b>PLENUM 3 GRILLES</b>
<b>B96A-B97A</b> .....	<b>PLENUM 3 GRILLES INSULATION</b>
<b>B96B-B97B</b> .....	<b>PLENUM 3 GRILLES + DAMPER</b>
<b>B96C-B97C</b> .....	<b>PLENUM 3 GRILLES INSULATION +DAMPER</b>
<b>B96D</b> .....	<b>PLENUM FILTER EPM1 50%</b>
<b>B96E</b> .....	<b>PLENUM FILTER EPM1 50%+DAMPER</b>
<b>B96F</b> .....	<b>PLENUM SILENCED</b>
<b>B96G</b> .....	<b>PLENUM SILENCED+DAMPER</b>
<b>B96H</b> .....	<b>PLENUM SILENCED+1 GRILLE</b>
<b>B96I</b> .....	<b>PLENUM SILENCED+1 GRILLE+DAMPER</b>
<b>B97D</b> .....	<b>PLENUM FILTER COARSE 60% TASCA</b>
<b>B97E</b> .....	<b>PLENUM FILT COARSE 60% TASCA+DAMPER</b>
<b>B97F</b> .....	<b>PLENUM FILTER COARSE 60%</b>
<b>B97G</b> .....	<b>PLENUM FILTER COARSE 60%+GRILLE N.A.</b>
<b>B97H</b> .....	<b>PLENUM FREE-COOLING</b>
<b>A531 (6)</b> .....	<b>DAMPER ON-OFF. THE NON-RETURN DAMPER IS CONTAINED IN A FRAME INSTALLED ON THE AIR SUPPLY OF THE MACHINE.</b>
<b>B981</b> .....	<b>SUPPORTING FRAME H255-450MM</b>
<b>B982</b> .....	<b>SUPPORTING FRAME H450-750MM</b>
<b>B983</b> .....	<b>SUPPORTING FRAME H750-1000MM</b>
<b>B991</b> .....	<b>INSULATION INSULATION</b>
<b>9969</b> .....	<b>NYLON PACKAGING, WOODEN CAGE</b>
<b>9976</b> .....	<b>PALLET AND NYLON PACKING</b>

## MANDATORY COMBINATIONS OF ACCESSORIES

1. The presence of the "6461 - HPC software enabling" accessory requires the presence of the "1441 - Kiplink + COMPACT KEYBOARD" accessory
2. The presence of the accessory "B97H - PLENUM FREE-COOLING" requires obligatorily the presence of accessory "A812 - Direct free cooling management".
3. The presence of accessory "P051 - Dehumidification function" obligatorily requires the presence of accessory "P161 Air intake T/rh probe".
4. The presence of the "A812 Direct free-cooling management" accessory obligatorily requires the presence of the "P161 T/rH probe air intake" accessory
5. The presence of accessories "4303 / 4305 Vapour humidifier" requires obligatory presence of accessory "P161 T/rH probe air intake".
6. The presence of the accessory "A531 On-off damper" requires obligatorily the presence of the accessory "9969 Wood cage packing".

## ACCESSORIES: B263 - OVER AIR DELIVERY – BOTTOM INTAKE

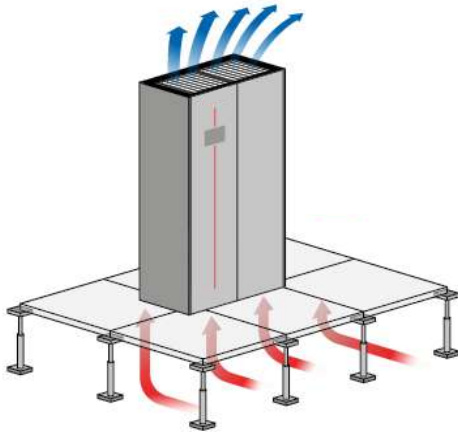

Available for OVER units.

Thanks to the special design of the base, it is possible to provide air intake from the bottom of the unit. The air flow rate is the nominal one.

The accessory provides for blind front panelling and is incompatible with the unit's internal filters.

P083 AIR FILTER COARSE 60%

P084 AIR FILTER ePM10 50%

It is necessary to provide filtering of the air entering the machine. In the case of combination with a plenum with filters, it is necessary to guarantee access to the filters for cleaning and replacement operations.

## OPTIONAL ACCESSORIES: B266 - FRONT. AIR DELIVERY – TOP INTAKE

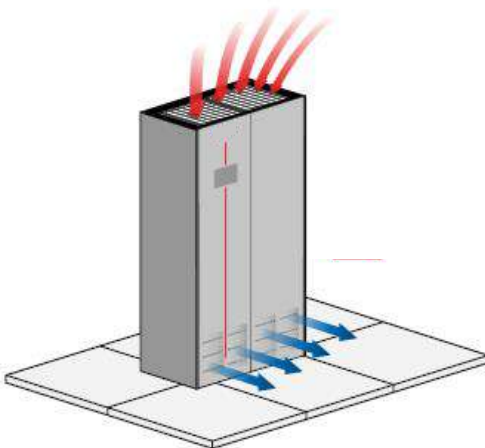

Available for UNDER versions, the accessory provides a grille to front panel to ensure front air delivery, we recommend the combination with a plenum with grille to improve system performance.

The accessory is suitable for application in server rooms where it is not possible to provide a raised floor or ducting of the air supply, where there are server racks with ventilated front and rear doors.

The typical installation is of the perimeter type, the units are positioned along the walls of the room, the units draw in air from the top and send it horizontally into the cold aisle for cooling the racks. Warm air is expelled from the racks at the top or from the back.

## OPTIONAL ACCESSORIES: B680 - CLOSING BASEMENT

Available for the OVER version with FRONTAL RECOVERY or UNDER version with accessory B266 "FRONTAL RECOVERY - HIGH RECOVERY", the accessory provides a panel to close the base of the unit, which prevents the flow of air in the lower part of the machine.

## OPTIONAL ACCESSORIES: 601 - SOLENOID VALVE ON LIQUID LINE



The accessory has the function of closing the liquid line, in the event of the machine stopping or blackout, avoiding the risk of liquid refrigerant migration into the evaporator.

Recommended accessory for:

- Refrigerating lines greater than 10m in equivalent length.
- Machines equipped with electronic expansion valve.

## OPTIONAL ACCESSORIES: A547 – COSTANT AIR FLOW

The accessory provides for the installation of a differential pressure transducer which allows the fan speed to be regulated guaranteeing the flow rate set-point that can be set by the controller, within the limits established by the manufacturer.

With the intervention of the functions that require modulation of the fan flow rate (humidification, dehumidification, heating with electric heaters) the constant flow rate control is temporarily deactivated to leave room for regulation.

## OPTIONAL ACCESSORIES: A548 – COSTANT PRESSURE



The optional is a differential pressure sensor with a 0...20mA output signal. The device is installed in the machine.

The sensor is connected to the microprocessor control of the indoor unit and allows the control of:

A548 - CONSTANT PREVALENCE

The system controls the air pressure in the raised floor (Under version) or in the duct (Over version). Through the relief piping of the room pressure (low pressure side) and the air supply of the fan (high pressure side) the fan rotation speed is controlled to keep the air pressure constant. Pressure control range from 0 to 100 Pa.

## OPTIONAL ACCESSORIES: B796 – POWER SUPPLY 380/3+N/60

## OPTIONAL ACCESSORIES: B796B - POWER SUPPLY 380/3/60

## OPTIONAL ACCESSORIES: B796 - POWER SUPPLY 380/3+N/60

## OPTIONAL ACCESSORIES: B798 - POWER SUPPLY 460/3+N/60

## OPTIONAL ACCESSORIES 383 – NUMBERED WIRINGS + UK REQUESTS

The machine's electrical cables are all numbered for easy identification. For the power section it is possible to change the colour for the UK market.

CABLE	383 - COLOUR FOR UK
EARTH	YELLOW / GREEN
NEUTRAL	BLUE SKY
PHASE 1 (L1)	BROWN
PHASE 2 (L2)	BLACK
PHASE 3 (L3)	GREY
PHASE	RED

## OPTIONAL ACCESSORIES: P181 – NETWORK ANALYZER



This device provides continuous measurement of power consumption, monitoring current, voltage and power. These values are sent to unit microprocessor via RS485 serial cable, as shown on the unit wiring diagram.

The displayed variables are:

- Phase to phase voltage, only for three-phase units;
- Phase voltage (phase-neutral);
- Phase current;
- Neutral current only for three-phase units;
- Active phase power, only for three-phase units;
- Total active power;
- Active energy;
- Hour counts



### INTERNAL INSTALLATION

The optional is installed within the electrical box downstream the main switch with door safety lock and includes:

- Network transducer;
- Current transformers, one for each power supply phase cable.

## OPTIONAL ACCESSORIES: P111 – DUAL POWER SUPPLY

The accessory requires a mandatory neutral supply. The accessory is not available for voltages 460/3/60 and 460/3+N/60.

The ATS system constantly monitors the power line and switches in the event of voltage anomalies or a phase failure. The system can be set up with 2 operating logics:

### 1. Line 1 priority:

In the event of a fault on line I, the system switches to line II; once the fault on line 1 has been resolved, the system switches back to the priority line.

### 2. No priority line.

In the event of a fault on line I the system swaps over to line II, the return to line I only takes place in the event of a fault on line II

Manual operation is also possible by inserting the handle into the ATS.

For continuous operation of the unit, the combination of the dual power supply with the fast restart system is recommended: in the event of a power failure, the fast restart system keeps the microprocessor powered for a few minutes, preventing it from restarting.

The remote capacitor must be powered by the automatic switch. We recommend the accessory: "P191 Remote condenser power supply" from the electrical panel of the indoor unit". If accessory "P181 Mains analyser" is selected, it is not possible to select accessory P111 Dual power supply, but only "P113 Dual power supply kit".



## OPTIONAL ACCESSORIES: P113 - KIT DUAL POWER SUPPLY

The 'P113 - DOUBLE POWER SUPPLY KIT' accessory is supplied as a kit with an IP3X-rated containment box.



## OPTIONAL ACCESSORIES: 4180 - WITHOUT SERIAL CARD OPTIONAL

### ACCESSORIES: 4181 - MODBUS PROTOCOL SERIAL CARD



The board is installed at the factory.  
The serial board allows the ModBus communication protocol to be used via the RS485 3-wire physical connection.

### OPTIONAL ACCESSORIES: 4182 - LON PROTOCOL SERIAL CARD



The board is installed at the factory. The serial board allows the LonWorks communication protocol to be used via the FTT-10 physical connection. The manufacturer provides the serial card and the .NXE and .XIF files necessary for LonWorks engineers to configure the network. The board is programmed by the technician in charge of integration. For all technical information, refer to the Interface Manual

### OPTIONAL ACCESSORIES: 4184 - BACNET MS/TP RS485 SERIAL CARD



The board is installed at the factory. The serial board allows the BACnet MS/TP communication protocol to be used via the 3-wire RS 485 physical connection. For all technical information, please refer to the Interface Manual.

### OPTIONAL ACCESSORIES: 4185 - BACNET OVER IP SERIAL CARD



The board is installed at the factory.  
The serial board allows the use of BACnet IP, Modbus TCP/IP and SNMP communication protocols via the physical Ethernet standard. The supervision network is realised by the technicians who develop the BACnet interfacing. The interfacing database is that for the Modbus protocol. The manufacturer will supply the boards and the .MIB file necessary for the technicians to configure the network.  
The programming of the board is the responsibility of the integrator. Please refer to the Interfacing Manual for all technical information and what is necessary to connect to the Internet for displaying and modifying variables. The board is installed at the factory.  
The serial board allows the use of BACnet IP, Modbus TCP/IP and SNMP communication protocols via the physical Ethernet standard. The supervision network is realised by the technicians who develop the BACnet interfacing. The interfacing database is that for the Modbus protocol. The manufacturer will supply the boards and the .MIB file necessary for the technicians to configure the network.  
The programming of the board is the responsibility of the integrator. Please refer to the Interfacing Manual for all technical information and what is necessary to connect to the Internet for displaying and modifying variables.



## OPTIONAL ACCESSORIES: 6461 - HPC (DF VERSION)

# HPC

Hydronic Plant Connect

HPC is the new advanced and fully integrated control function designed by MEHITS for hydronic plant optimization. It connects MEHITS chillers and indoor CRAH units without any external devices.

### INFRASTRUCTURE

The HPC function is based on LAN groups and the KIPLink network (KIPLAN).

- Every indoor and outdoor unit must be equipped with KIPLink.
- Every outdoor unit must be equipped with Multi Manager.
- HPC supports up to 20 LAN groups of indoor air conditioners (max 15 units per group) and 1 LAN group of outdoor chillers (max 8 units).
- HPC requires a KIPLAN (KIPLink network) made up of one unit per each LAN group. The result is a KIPLAN made of 1 chiller unit (KIP Master), and up to 20 indoor units (KIP Clients).

The result is a KIPLAN made of 1 chiller unit (KIP Master), and up to 20 indoor units (KIP Clients).

KIPLAN network allows HPC data communication between the different LAN groups (indoor and outdoor).

KIPLink allows direct access to all HPC variables and parameters with devoted menus and pages.

The most important parameters are also available on the Compact/Large Keyboard.

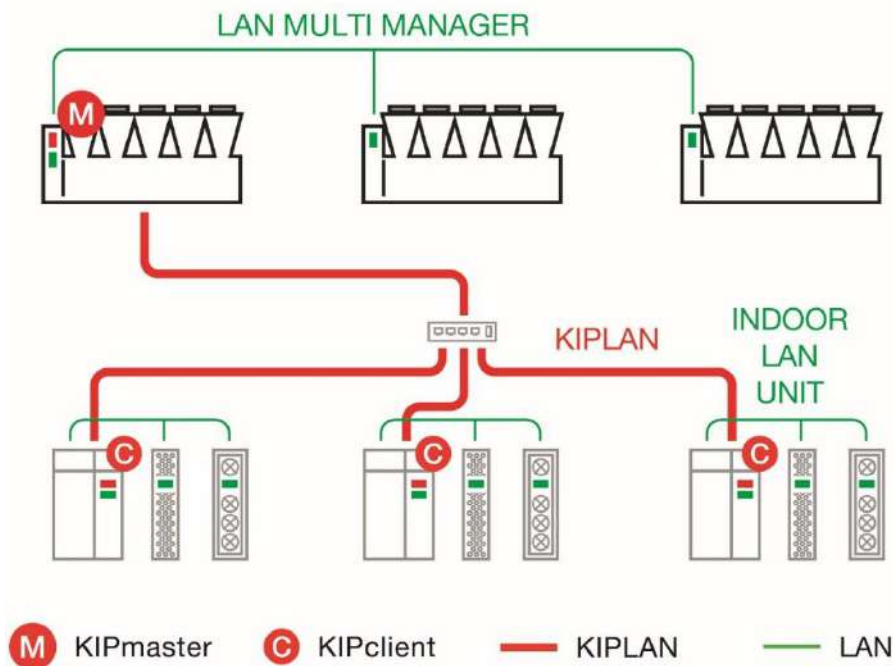

Further information is available in the dedicated Manuals (W3000+, Evolution+, KIPLink).

### WORKING LOGICS

The HPC control logics enhance the system efficiency leveraging on partial loads, redundant units, and favourable ambient conditions.

HPC acts on time intervals. The time lapse between each HPC action can be set from 1 to 500 minutes. The time left until the AV action is visible in the KIPLink group interface section.

According to the instantaneous operating conditions detected in the chilled water system, HPC regulates: the chillers' set-point, the pumps' speed, and the indoor air conditioners' valves and fans.

The main variables taken into consideration are:

- Cooling demand of each indoor unit group (room temperature, fans' speed, valve opening)
- Chilled water temperature
- Pumps' speed
- Chillers' group operating status (outdoor air temperature, FC availability)

The highest benefits are achieved in systems with VSD pumps and free-cooling chillers.

The highest benefits are achieved in systems with VSD pumps and free-cooling chillers.

IT cooling load satisfaction is paramount. HPC always gives priority to room cooling dependability. Therefore, actions are taken on the basis of the indoor unit groups' status.

There are 4 operating modes, in order of priority:

1. Reset

When the cooling demand of at least one group of indoor units suddenly increases. HPC contribution is reset and suspended until the Reset message is active. The system immediately increases the cooling capacity.

2. Reduce

When the cooling demand of at least one group of indoor units slightly increases. HPC contribution is reduced. The system increases the cooling capacity.

3. Optimization On

When the cooling demand of all groups of indoor units remains stable or decreases. HPC optimizes the system by increasing its contribution.

4. No Action

When the cooling demand of all groups of indoor units remains stable or decreases, but HPC has already pushed the system to the best performance achievable in the current conditions.

No further action is taken.



**PLUS**

- Fully in house developed and patent pending
  - Completely integrated, no need for any external devices
  - Based on proprietary logics and devices (Multi Manager, KIPLink)
  - Energy simulations, comparisons, and payback analysis available on ELCA software
- Ideal to complete the package of a MEHITS chilled water system (chillers and CRAHs)

- OPTIONAL ACCESSORIES: 1441 - CONTROL UNIT VIA KIPLINK + COMPACT KEYBOARD**
- OPTIONAL ACCESSORIES: 1442 - CONTROL UNIT VIA KIPLINK + 7 INCH TOUCH SCREEN**
- OPTIONAL ACCESSORIES: 6192 - COMPACT KEYBOARD**
- OPTIONAL ACCESSORIES: 6196 - CONTROL UNIT VIA KIPLINK**

The optional is factory installed.

KIPLink is an innovative system based on Wi-Fi technology that allows to operate on a unit directly from Smartphone or Tablet via an APP. The optional is factory installed.



### WI-FI MODULE

- Standard: IEEE 802.11n - 802.11g
- Frequencies: 2.4 - 2.4835 GHz
- Output power: <20 dBm (equivalent to <100mW)
- Safety: WPA2
- Flow: < 20m

### APP MEHITS

Operating System: Android 5® or higher, IOS 8® or higher, Windows 10® or higher

Download: Google Play®, Apple Store® and Microsoft Store®.

### HOW TO USE KIPLINK

KIPLink can be used in three ways:

#### Proximity keyboard:

Approaching the machine with a Smartphone or a Tablet with the MEHITS APP installed, you can connect to the unit via Wi-Fi and you can control it as you would from the standard controller keyboard. It is possible to switch the unit on and off, change the sets and reset alarms. Knowing the relative passwords, you access the parameters of the USER, SERVICE and MANUFACTURER menus.

#### Local Monitoring:

Using a Smartphone, a Tablet or PC connected to the LAN of the building where the unit is also connected. Access is via WEB via a browser. The system has two access profiles: ONLY READ and READ & WRITE.

ONLY READ allows only the visualization of the parameters and it is not possible to control the unit.

READ & WRITE allows you to switch the unit on and off, change the sets and reset alarms. Knowing the relative passwords, you access the parameters of the USER, SERVICE and MANUFACTURER menus.

#### Remote monitoring:

You can use a Smartphone, Tablet or PC connected to the VPN of the building where the unit is also connected to monitor the unit from any geographical location where there is an internet connection. Use a secure VPN to avoid access by third parties who could compromise operation of the unit. The user is responsible for ensuring a secure connection.



### STORING DATA

The system can store some data on a 1GB MicroSD card to be installed on the device. The data can be used for Service diagnostics. The card is not provided.

### KIPLINK NETWORK

It is possible to set up mixed networks consisting of several KIPLink devices (10 maximum), to display information from different devices (called Client KIPLink) on one single device (called Master KIPLink).

The information is collected from the various Client KIPLink devices connected to EVOLUTION+ / W3000 TE/ CX-4 controllers and sent through the Wi-Fi or Ethernet network to the Master KIPLink device, which stores them and makes them available through an appropriate user interface. The connection with the Master KIPLink can take place via Wi-Fi, via Ethernet or a combination of the two. For complete information on the KIPLink system, please consult the relative technical documentation.

## OPTIONAL ACCESSORIES: 6195 - COMPACT 7 INCH TOUCH SCREEN



The optional is factory installed.

7" touch-screen graphic display with 16.7 million colors for the management and monitoring of operating and alarm status.

The Display is equipped with a MicroUSB 2.0 port for the service connection.

The navigation bars are always present on the display to allow quick and intuitive navigation.

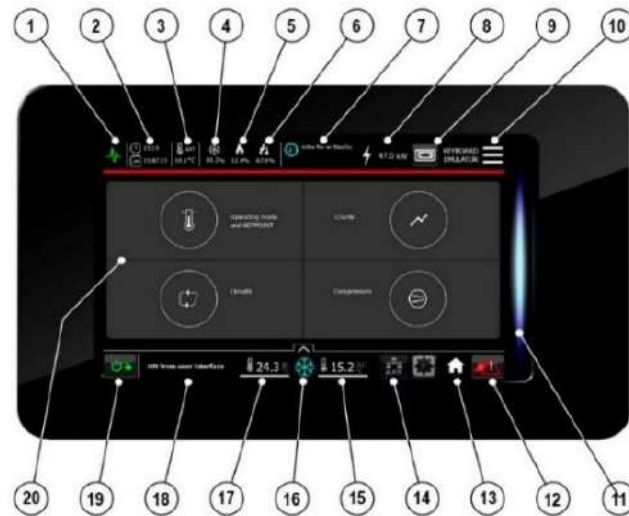

### TOP NAVIGATION BAR

1. Status of connection with the controller. Green: connection OK; Red: connection Error
2. Time and date
3. External temperature value by dedicated probe
4. Active percentage of Cooling
5. Active percentage of Heating
6. Active percentage of Post-Heating
7. Unit active functions
8. Power meter readings
9. PGD1 keyboard emulator
10. Rapid access to the menu (Quick menu)

### BOTTOM NAVIGATION BAR

11. Light bar for machine status identification
12. Alarm button to access the alarm management screen and the number of active alarms
13. Home button for returning to the Homepage
14. pLAN network
15. Temperature of outlet air or percentage of humidity.
16. Operating mode button.
17. Inlet air temperature
18. Unit status
19. On/Off button

### DISPLAY AREA

20. Main menu
  - a. Operating mode and Set-Point
  - b. Circuits
  - c. Charts
  - d. Compressors

For complete information on Graphic Display system, please consult the relative technical documentation.

## OPTIONAL ACCESSORIES: C9261063 – REMOTE DISPLAY



The display is supplied but not installed at the factory.  
If a group of units is connected via LAN (UP TO 15), it is possible to view all the parameters of each individual unit via a single display.  
The display kit consists of:  
- a PGD physical keyboard  
- a 1 m cable  
- a T shunt card

## OPTIONAL ACCESSORIES: P151 – LOWERED DISPLAY FOR UNDER

The accessory is recommended for UNDER units when the plenum on the air supply is provided.  
The display/keyboard located on the front panel of the machine is installed lowered by 51 cm to facilitate its consultation and use. The accessory is not compatible with touch displays.

## OPTIONAL ACCESSORIES: A492 - WATER LEAKAGE DETECTOR + ADDITIONAL DETECTOR



The system includes an electronic relay installed in the electrical panel of the indoor machine and 2 water detectors to be connected in series.  
The electrical connections for the probe and the alarm contact are present in the indoor machine's terminal board.  
The sensors are supplied to be connected and installed at customer care.

## OPTIONAL ACCESSORIES: A511 - SMOKE DETECTORS



Is possible to install one or both of the following sensors. Sensors are supplied in mounting kit. Installation within the room at customer care.  
The device is supplied in mounting kit.  
The optical smoke detector senses the presence of combustion by-products (visible smoke) and activates an alarm.  
The operating principle is based on the light scattering technique (Tyndall effect).  
The device is in conformity to EN 54-7 standard.

Technical features:

Material	ABS	Relative humidity	<93% not-condensing
Power supply	12...28 Vdc	Index of protection	IP 20
Normal current	50µA 24 Vdc	Testing by magnet	Yes
Alarm current	25mA 24 Vdc	Relay	max. 1A 30Vdc
LED visibility	360° (double	Signal repeater	14mA 24 Vdc
Storage	-10...+70°C	Covered area	40m2 max.
Operating	-10...+70°C	Shielded connection	Min. 0.5 mm2
Max. speed air	0.2 m/s	Colour	White

Supplied with unit to be connected and installed at customer care close to the unit.

## OPTIONAL ACCESSORIES A521 – FIRE DETECTOR

The device is supplied in mounting kit.

The fire detector has been designed to identify temperatures at which fires may start. When the temperature exceeds the set threshold or when there is a rapid variation in temperature, the relay is activated to signal an alarm. The device is in conformity to EN 54-5 standard.

Technical features:



Material	ABS	Index of protection	IP 20
Power supply	12...28 Vdc	Testing by magnet	Yes
Normal current	50µA 24 Vdc	Relay	max. 1A 30Vdc
Alarm current	25mA 24 Vdc	Signal repeater	14mA - 24 Vdc
LED visibility	360° (double LED)	Alarm temperature threshold	62°C
Storage temperature	-10...+70°C	Covered area	40m2 max.
Operating temperature	-10...+70°C	Shielded connection cable	Min. 0.5 mm2
Relative humidity	<93% non-	Colour	White

Supplied with unit to be connected and installed at customer care close to the unit.

## OPTIONAL ACCESSORIES B811 – AIR FLOW SENSOR



The system includes a differential pressure switch installed in the electrical cabinet or in the front compartment of the machine and the plastic piping for pressure measurement at the fan inlet.

Operating range: 0.2 ... 2.0 mbar (20 ... 200 Pa)

Tripping differential: 0.1 mbar (10 Pa)

Tripping value fixed at 0.2 mbar, cannot be changed.

## OPTIONAL ACCESSORIES 4503 - FAST RESTART (ULTRACAP )



The accessory is installed inside the unit's electrical panel.

In the event of brief blackouts or power surges, it keeps the unit's microprocessor powered for a few minutes and ensures the rapid resumption of machine operation when normal power supply conditions are restored.

## OPTIONAL ACCESSORIES 2412 - PHASE SEQUENCE CONTROL



The system monitors the correct sequence of the power supply phases and the status of the supply voltage, intervening in the event of undervoltage, overvoltage and incorrect phase rotation.

The accessory is installed in the electrical panel downstream from the main lockout switch and in the event of an alarm stops the unit's operation or prevents it from starting.



**OPTIONAL ACCESSORIES ACCESSORI: A381 – KIT CONDENSATE DRAIN PUMP**

The accessory is supplied in kit form and involves the installation outside the machine of a condensate booster pump equipped with a tank with a microswitch float switch to activate the pump. Together with the pump, 10 metres of anti-crushing spiral-type discharge pipe is supplied. Operation of the pump is fully automatic, and any pump faults and overfilling can be seen by the controller. The pump is suitable for the evacuation of humidifier discharge water, if fitted.

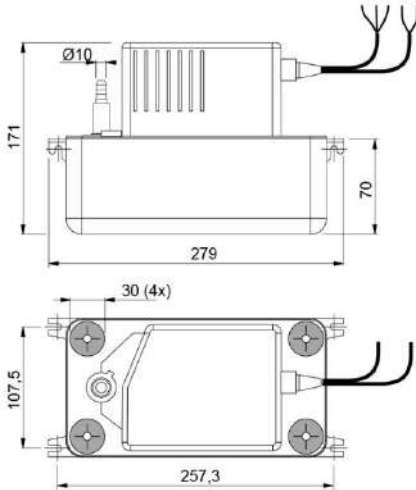

**WARNINGS**  
**Maximum delivery height: 5.0 m**  
For all the machines the optional accessory is supplied in mounting kit.

**TECHNICAL DATA**  
Power supply: 230V~ 50Hz  
Electrical data: 70W – 0,67A  
Maximum water flow: 500 l/h  
Maximum delivery height: 5.0 m  
Sound level: 45dBA a 1 m  
Maximum water temperature: 70°C  
Water acidity: pH>2.5  
Tray volume: 2.0 l  
Protection IP 20

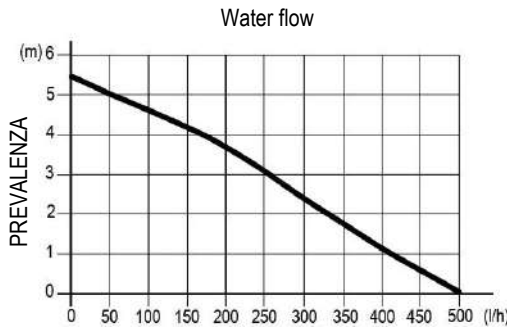
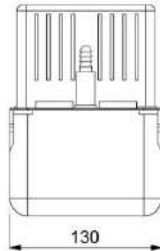

Discharge head	Total length of discharge pipes (Ø 10 mm internal)			
	5m	10m	20m	30m
1m	380	300	240	190
2m	310	260	200	150
3m	240	200	145	110
4m	150	130	80	60
5m	30	20	0	0

**OPTIONAL ACCESSORIES: A812 – WITH DIRECT FREE-COOLING**

Preparation of the machine and control cabinet for direct free-cooling system, combination with "B97H - PLENUM FREE COOLING" accessory required.

**OPTIONAL ACCESSORIES: A791 - AIR TEMPERATURE CONTROL ON SUCTION AIR.**

Machine set-up for room air temperature control with probes on air intake.

## OPTIONAL ACCESSORIES: B803 – 3-WAY VALVE (VERSION DF)

3-way motorised valve with 0÷10 VDC control and emergency manual override, for creating the third by-pass route in the hydraulic circuit.

The accessory is factory installed inside the unit and does not change its overall dimensions.

This type of valve offers the following set of benefits:

- Equipercantage characteristic
- Absence of initial flow peaks
- Excellent control stability due to the control disc
- Excellent partialisation characteristic
- Control stability
- Maintenance-free
- Self-cleaning

### 3-WAY BALL VALVE FEATURES

- Sealed with leakage rate class A (EN 12266-1)
- Maximum fluid pressure  $P_s=1600\text{kPa}$
- Maximum closing pressure (Close-off)  $\Delta P_s=1400\text{kPa}$

The rotary actuator is controlled by a 0 ... 10 VDC signal from the microprocessor control. The actuator is equipped with an emergency manual override button and is maintenance-free.

Model		29	40	51	52	67	76	78	90	108	140
Frame		M	M	M	L	L	L	XL	XL	XL	XL
<b>3-way valve</b>											
kv	[m <sup>3</sup> /h]	16	16	16	16	16	16	-	-	-	-



## OPTIONAL ACCESSORIES: B807 - 2-WAY VALVE EPIV (Version DF)



Accessory to the cooling coil and replaces the 2-way valve. Pressure-independent EPIV regulating ball valve with electronic flow control. The accessory is factory installed inside the unit and does not change its overall dimensions.

This valve type offers the following set of benefits:

- Equipcentage characteristic and control disc.
- Excellent control stability regardless of pressure variations and under all load conditions.
- Maintenance-free.
- Self-cleaning.

### EPIV VALVE FEATURES

- Sealed with leakage rate class A (EN 12266-1).
- Maximum fluid pressure  $P_s=1600\text{kPa}$ .
- Maximum closing pressure (Close-off)  $\Delta P_s=1400\text{kPa}$ .
- Maximum differential pressure  $\Delta P_{max}=350\text{kPa}$ .

**The rotary actuator is controlled by a 0 ... 10 VDC signal and is optimised for this valve type. The valve opens by turning anti-clockwise and closes by turning clockwise. The actuator is equipped with a button for manual emergency operation and is maintenance-free..**

Model		29	40	51	52	67	76	78	90	108
FRAME		M	M	M	L	L	L	XL	XL	XL
2 WAY VALVE										
kv	[m <sup>3</sup> /h]	14,2	14,2	14,2	21,3	21,3	21,3	32	32	32

## OPTIONAL ACCESSORIES: P201 – 2-WAY VALVE (Version DW and DW DF)



The accessory is standard for DW FC versions

The accessory, mounted at the condenser outlet, includes a motorised 2-way valve for condensation control with 0-10 VDC control and manual emergency control.

Water flow control is performed by a 2-way modulating ball valve of the equipcentage type with characterisation disc. The accessory is standard for DW FC versions.

The accessory, mounted at the condenser outlet, includes a motorised 2-way valve for condensation control with 0-10 VDC control and manual emergency control. water flow control is performed by a 2-way modulating ball valve of the equipcentage type with characterisation disc.

This type of valve offers the following set of benefits:

- Equipcentage characteristic.
- Absence of initial flow peaks.
- Excellent control stability due to the control disc.
- Excellent partialisation characteristic.
- Control stability.
- Maintenance-free.
- Self-cleaning.

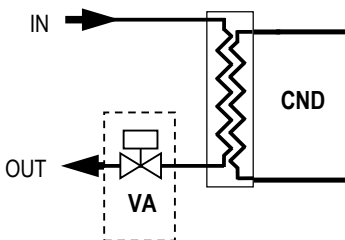

## 2-WAY BALL VALVE FEATURES

- Sealed with leakage rate class A (EN 12266-1)
- Maximum fluid pressure  $P_s=1600\text{kPa}$
- Maximum closing pressure (Close-off)  $\Delta P_s=1400\text{kPa}$

The rotary actuator is controlled by a 0 ... 10 VDC signal from the microprocessor control. The actuator is equipped with an emergency manual override button and is maintenance-free.

Model		29	40	51	52	67	76	78	90	108	140
Frame		M	M	M	L	L	L	XL	XL	XL	XL
<b>2-way valve</b>											
kv	[m <sup>3</sup> /h]	16	16	16	25	25	25	40	40	40	40

## OPTIONAL ACCESSORIES: A431 – ELECTRIC HEATERS

Electric heater consisting of finned aluminum elements, ensuring low surface temperature and deleting the air ionization problems. The optional is installed downstream the main cooling coil.

In electric heaters with three working steps the activation is binary type.

Components:

- Electric heater in aluminium armoured elements with integral fins
- Electrical control
- Safety thermostat.

Temperature control on suction air.

### TECHNICAL DATA

AIR SUPPLY (1)		U / O	U / O	U / O	U / O	U / O
MODEL		29	40	51	52	67
FRAME		M	M	M	L	L
HEATING CAPACITY	kW	6,8	6,8	6,8	13,5	13,5
Absorbed current (OA)	A	9,8	9,8	9,8	19,5	19,5
First working step	kW	2,3	2,3	2,3	4,5	4,5
Second working step	kW	4,5	4,5	4,5	9,0	9,0
Third working step	kW	2,3 + 4,5	2,3 + 4,5	2,3 + 4,5	4,5 + 9,0	4,5 + 9,0

AIR SUPPLY (1)		U / O	U / O	U / O	U	U
MODEL		76	78	90	108	140
FRAME		L	XL	XL	XL	XL
HEATING CAPACITY	kW	13,5	18	18	18	18
Absorbed current (OA)	A	19,5	26	26	26	26
First working step	kW	4,5	6,3	6,3	6,3	6,3
Second working step	kW	9,0	11,7	11,7	11,7	11,7
Third working step	kW	4,5 + 9,0	6,0 + 12,0	6,0 + 12,0	6,0 + 12,0	6,0 + 12,0

1. U = Under, supply aria verso il basso / O = Over, supply aria verso l'alto
2. Valore da sommare al peso dell'unità standard

## OPTIONAL ACCESSORIES: P051 – DEUMIDIFICATION FUNCTION

The accessory "P161 T/RH air intake probe" must be present.

Components:

- T / rH air intake probe.
- Electronic dew-point temperature control system for combined intervention of cooling power output and air flow rate

## OPTIONAL ACCESSORIES: 4303 - HUMIDIFIER VAP. 8 kg/h UM08

## OPTIONAL ACCESSORIES: 4305 - HUMIDIFIER VAP. 15 kg/h UM15

- Accessory not available for 460/3/60 and 460/3+N/60 power supply.
- Immersed electrode modulating steam humidifier equipped with electronic control with modulating steam delivery, complete with safety and operating accessories.
- A metal cover over the kettle ensures high levels of safety during operation.
- Flammability safety standard UL94: V0.
- The accessory includes the combined air intake temperature/humidity probe and control board.
- The accessory is factory fitted and only requires a hydraulic connection for water filling.
- Water is discharged from the humidifier directly into the unit's condensate drain pan and is then conveyed to the outside via the condensate drain pipe.
- It is recommended to install a FILTER and a shut-off valve on the water inlet pipe.

## CHARACTERISTICS OF THE SUPPLY WATER

The quality of the used water influences the evaporation process, so the humidifier can be fed with not-treated water, only when potable and non-demineralised

## LIMIT VALUES



Humidifier control board

		Min	Max
Hydrogen ions	pH	7	8,5
Specific conductivity at 20°C	$\sigma_R, 20^\circ\text{C}$ $\mu\text{S/cm}$	350	750
Total dissolved solids	TDS $\text{mg/l}$	(1)	(1)
Dry residue at 180°C	$R_{180}$ $\text{mg/l}$	(1)	(1)
Total hardness	TH $\text{mg/l CaCO}_3$	100 (2)	400
Temporary hardness	$\text{mg/l CaCO}_3$	60 (3)	300
Iron + Manganese	$\text{mg/l Fe + Mn}$	0	0,2
Chlorides	ppm Cl	0	30
Silica	$\text{mg/l SiO}_2$	0	20
Residual chlorine	$\text{mg/l Cl}^-$	0	0,2
Calcium sulphate	$\text{mg/l CaSO}_4$	0	100
Metallic impurities	$\text{mg/l}$	0	0
Solvents, diluents, soaps, lubricants	$\text{mg/l}$	0	0

1. Values depending on specific conductivity; in general:  $\text{TDS} \cong 0,93 * \sigma_R, 20^\circ\text{C}$ ;  $R_{180} \cong 0,65 * \sigma_R$
2. Not lower than 200% of the chloride content in  $\text{mg/l di Cl}^-$
3. Not lower than 300% of the chloride content in  $\text{mg/l di Cl}^-$

### WARNING:

- Use only with drinking water.
- There is no reliable relationship between hardness and water conductivity
- Do not treat water with softeners! This could cause corrosion of the electrodes or the formation of foam, leading to potential operating problems or failures.
- Do not add disinfectants or corrosion inhibitors to water, as these substances are potentially irritant.
- Is absolutely forbidden to use well water, industrial water or water drawn from cooling circuits; in general, avoid using potentially contaminated water, either from a chemical or bacteriological point of view.

## TECHNICAL DATA

		U/O	U/O	U/O	U/O	U/O	U/O	U/O	U/O	U/O	U/O	U/O
		29	40	51	52	67	76	78	90	108	140	
		M	M	M	L	L	L	XL	XL	XL	XL	
<b>VAPOUR PRODUCTION</b>	kg/h	8	15	8	8	8	8/15	8/15	8/15	8/15	8/15	8/15
Power input	kW	6	11,3	8	8	8	8/15	8/15	8/15	8/15	8/15	8/15
Absorbed current (OA)	A	8,7	16,2	8	8	8	8/15	8/15	8/15	8/15	8/15	8/15
Max absorbed current (OA)	A	12,4	23	8	8	8	8/15	8/15	8/15	8/15	8/15	8/15
Water content	l	6,4	10,3	8	8	8	8/15	8/15	8/15	8/15	8/15	8/15
Max water supply pressure	Bar	1÷8	1÷8	8	8	8	8/15	8/15	8/15	8/15	8/15	8/15
<b>NET WEIGHT (2)</b>	kg	10	16	8	8	8	8/15	8/15	8/15	8/15	8/15	8/15
<b>HYDRAULIC CONNECTION</b>				8	8	8	8/15	8/15	8/15	8/15	8/15	8/15
WATER INLET - ISO 228/1 – G M	Ø	3/4"	3/4"	8	8	8	8/15	8/15	8/15	8/15	8/15	8/15
WATER OUTLET – external diameter	Ø mm	19	19	8	8	8	8/15	8/15	8/15	8/15	8/15	8/15

1. U = Under, downflow / O = Over, upflow
2. Value to be added to the weight of the standard unit. Does not include the weight of the water content.

## OPTIONAL ACCESSORIES: P161 – RETURN AIR PROBE T/RH

The accessory replaces the temperature probe installed on the air intake in the indoor unit.  
The probe is supplied with the following options:

- Humidifier INSTALLATION.
- Dehumidification system.

## OPTIONAL ACCESSORIES P071 – REMOTE PROBE T/RH (1 probe)

## OPTIONAL ACCESSORIES P072 - REMOTE PROBE T/RH (2 probe)

## OPTIONAL ACCESSORIES P073 - REMOTE PROBE T/RH (3 probe)

## OPTIONAL ACCESSORIES P074 - REMOTE PROBE T/RH (4 probe)



In addition to the on-board temperature probes, the unit's control can manage up to 4 remote T/RH probes (optional), to measure the return and the delivery air temperature in different positions.

Depending on the individual characteristics of the room and the cooling equipment, the customer can choose where to install the additional probes to achieve best measurement results (N. add. return probes + N. add. delivery probes ≤ 4).

The probes can be configured from the Service menu of the controller.

The probes that are enabled, contribute to the calculation of the return and delivery temperature used for capacity adjustment purposes.

The customer can choose between different types of calculation:

- Temperature of the first probe enabled
- Average temperature of the probes
- Highest temperature of the probes
- Lowest temperature of the probes.

### Notes:

If a probe is connected but not enabled, its measurement can still be read on the display and by the BMS, but it is not used to calculate the adjustment temperature. It is possible to disable the probe on the unit and use only the remote probes for capacity adjustment purpose.

- **P071: One** Combined Temperature / Humidity sensor for remote installation. The optional is added to the on-board temperature sensors.
- **P072: Two** Combined Temperature / Humidity sensors for remote installation. The optional is added to the on-board temperature sensors.
- **P073: Three** Combined Temperature / Humidity sensors for remote installation. The optional is added to the on-board temperature sensors.
- **P074: Four** Combined Temperature / Humidity sensors for remote installation. The optional is added to the on-board temperature sensors

## OPTIONAL ACCESSORIES: P080 – WITHOUT AIR FILTER

The unit is supplied without air filters, improving the unit's energy efficiency. This configuration is only allowed when the unit is installed in a condition where the incoming air is already filtered (filtration system in the room, in the ducting, combination with plenum with filters on the unit's return)

## OPTIONAL ACCESSORIES: P084 – AIR FILTER ePM10 50%

Air filters with ePM10 50 per cent efficiency (according to ISO EN 16890), replacing standard filters, guarantee a higher degree of filtration combined with a long service life and minimal energy consumption

## OPTIONAL ACCESSORIES: P101 - KIT ANTI-SEISMIC ANCHORAGE

The accessory available for the indoor unit and supplied as an assembly kit consists of two lateral supports to be fixed to the sides of the unit and to the support surface.

This is a safety device that must be fitted by the customer before installing the unit and fixed to a structural part with adequate strength at the installation site to avoid the risk of displacement and/or overturning due to earthquakes.

Screws for fixing the unit to the structure are not supplied and fixing the unit to the structure is the responsibility of the Customer. To guarantee earthquake resistance, the unit must be secured to a structural part with adequate strength with 4 M10 steel screws (not supplied).

The presence of the "ANTISEISMIC ANCHORAGE KIT" accessory requires the installation of the "UNIT FIXING BRACKET".

The accessory excludes the installation of the plenum and unit support frame.

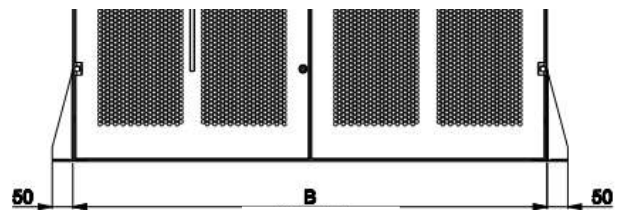
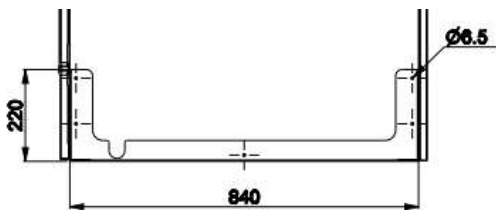

FRAME		M	L	XL
Dimension B	mm	1142	1930	2880

## OPTIONAL ACCESSORY: PLENUM

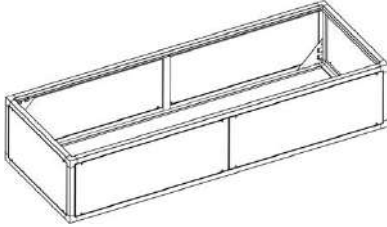

The x-AV3 series is supplied with a wide range of plenums to meet the most varied customer requirements.

The optimised structure guarantees easy installation of the plenum in the different configurations: using the connection devices supplied with the plenum, it is possible to connect the accessory to the machine from the inside (without compromising its aesthetics), quickly and easily.

The design guarantees front access for all devices requiring periodic maintenance. Removal of the filters from the front of the unit is always guaranteed.

Internal sheet steel panelling with protective surface treatment according to UNI ISO 9227/ASTMB117 and ISO 7253.

Aesthetic panels with wrinkled finish, front panels colour RAL 9006, side and rear panels colour RAL 7016, completely removable by removing the fixing screws.

Panelling insulated internally with polyurethane foam mattress.

The accessory is supplied separately and installation on the unit is the responsibility of the customer. The x-AV3 series is supplied with a wide range of plenums to meet the most varied customer requirements.

PLENUM		M	L	XL
Height	[mm]	510	510	510
Width	[mm]	1142	1930	2880
Depth	[mm]	882	882	882

## OPTIONAL ACCESSORY: B961/B971 - EMPTY PLENUM

## OPTIONAL ACCESSORY: B962/B972 - EMPTY PLENUM + INSULATION

The plenum is empty and can be used to raise the air intake/outlet point.

- The front panels can be removed for inspection or to remove the filters from the unit.
- Available in INSULATION version.

		M	L	XL
<b>INSTALLATION</b>				
UNDER	Supply	X	X	X
	Return	X	X	X
OVER	Supply	X	X	X
	Return			
<b>WEIGHT</b>		<b>M</b>	<b>L</b>	<b>XL</b>
EMPTY PLENUM	[kg]	53,3	63,6	87,6
EMPTY PLENUM + INSULATION	[kg]	60,2	74,4	102

## OPTIONAL ACCESSORY: B965/B975 - PLENUM 1 GRILLE

## OPTIONAL ACCESSORY: B969/B979 - PLENUM 3 GRILLES

## OPTIONAL ACCESSORY: B966/B976 - PLENUM 1 GRILLE + INSULATION

## OPTIONAL ACCESSORY: B96A/B97A - PLENUM 3 GRILLES + INSULATION

The plenum must be installed on both the supply and return lines of the machine and allows the flow of air to be directed.

- Available in the version with one GRILLE on the front panel
- Available in the version with one GRILLE on the front panel and one GRILLE for each side panel
- Front panels can be removed for inspection or to remove the filters from the unit
- Available in the version with INSULATION

# ACCESSORIES

x-AV3 DW / DW DF / DW FC

Data Book  
DB\_CV\_x-AV3-I-G02-DW\_102022\_EN\_rev00

		M	L	XL
<b>INSTALLATION</b>				
UNDER	Supply	X	X	X
	Return	X	X	X
OVER	Supply	X	X	X
	Return			
<b>WEIGHT</b>		<b>M</b>	<b>L</b>	<b>XL</b>
PLENUM + 1/3 GRILLES	[kg]	60,1	75,6	103,6
PLENUM + 1/3 GRILLES + INSULATION	[kg]	64,6	81	110,8

## OPTIONAL ACCESSORY: B963/B973 - EMPTY PLENUM + DAMPER

## OPTIONAL ACCESSORY: B964/B974 - EMPTY PLENUM + DAMPER + INSULATION

The plenum must be installed above the unit and allows the unit to be excluded from air circulation when it is in OFF mode.

- Front panels can be removed for inspection or to remove the filters from the unit
- Available in the version with INSULATION

		M	L	XL
<b>INSTALLATION</b>				
UNDER	Supply			
	Return	X	X	X
OVER	Supply	X	X	X
	Return			
<b>WEIGHT</b>		<b>M</b>	<b>L</b>	<b>XL</b>
PLENUM + DAMPER	[kg]	61,6	75,6	107,6
PLENUM + DAMPER + INSULATION	[kg]	68,8	86,4	122

## OPTIONAL ACCESSORY: B967/B977 - PLENUM 1 GRILLE + DAMPER

## OPTIONAL ACCESSORY: B96B/B97B - PLENUM 3 GRILLES + DAMPER

## OPTIONAL ACCESSORY: B968/B978 - PLENUM 1 GRILLE + DAMPER + INSULATION

## OPTIONAL ACCESSORY: B96C/B97C - PLENUM 3 GRILLES + DAMPER + INSULATION

The plenum must be installed on the delivery side of the unit and allows the flow of outgoing air to be directed; when the unit is in OFF, it is possible to exclude it from air circulation by closing the damper.

- Front panels can be removed for inspection or to remove the filters from the unit
- Available in the version with INSULATION

		M	L	XL
<b>INSTALLATION</b>				
UNDER	Supply			
	Return			
OVER	Supply	X	X	X
	Return			
<b>WEIGHT</b>		<b>M</b>	<b>L</b>	<b>XL</b>
PLENUM + 1/3 GRILLES + DAMPER	[kg]	69,6	88	123,6
PLENUM + 1/3 GRILLES + DAMPER + INSULATION	[kg]	73,2	93,2	130,8

## OPTIONAL ACCESSORY: B96F - PLENUM SILENCED OPTIONAL ACCESSORY: B96H - PLENUM SILENCED 1 GRILLE

The plenum must be installed on the discharge side of the machine and provides a noise reduction.

- Front panels can be removed for inspection or to remove filters from the unit
- Available in a version with a GRILLE on the front panel

		M	L	XL	
<b>INSTALLATION</b>					
UNDER	Supply	X	X	X	
	Return				
OVER	Supply	X	X	X	
	Return				
<b>WEIGHT</b>					
PLENUM SILENCED		[kg]	59	71,6	97,6
PLENUM + SILENCED + 1 GRILLE		[kg]	67	83,6	113,6

## OPTIONAL ACCESSORY: B96G - PLENUM SILENCED + DAMPER OPTIONAL ACCESSORY: B96I - PLENUM SILENCED + 1 GRILLE + DAMPER

The plenum must be installed on the delivery side of the machine and allows a reduction in noise, when the unit is in OFF mode it is possible to exclude it from air circulation by closing the damper.

- Front panels can be removed for inspection or to remove filters from the unit
- Available in a version with a GRILLE on the front panel

		M	L	XL	
<b>INSTALLATION</b>					
UNDER	Supply				
	Return				
OVER	Supply	X	X	X	
	Return				
<b>WEIGHT</b>					
SILENCED PLENUM + DAMPER		[kg]	67,6	83,6	117,6
SILENCED PLENUM + 1 GRILLE + DAMPER		[kg]	75,6	95,6	130,6

## OPTIONAL ACCESSORY: B96D - PLENUM + FILTER ePM 1 50%

The plenum with rigid pocket filters must be installed on the machine's supply air and provides additional filtering of the air leaving the unit, depending on the type of FILTER installed.

- Available with FILTER for particulate matter 1 µm, 50% efficiency
- Front panels can be removed for inspection or to remove the filters from the unit

		M	L	XL	
<b>INSTALLATION</b>					
UNDER	Supply	X	X	X	
	Return				
OVER	Supply	X	X	X	
	Return				
<b>WEIGHT</b>					
PLENUM + FILTER ePM 1 50%		[kg]	59	71,6	97,6



## OPTIONAL ACCESSORY: B96E - PLENUM + FILTER ePM 1 50% + DAMPER

The plenum with rigid bag filters in combination with the Damper must be installed on the unit's delivery side; it guarantees additional filtering of the air leaving the unit, depending on the type of FILTER installed, and the possibility of excluding the unit from air circulation when it is in OFF mode.

- Available with FILTER for particulate matter 1 µm, 50% efficiency
- Front panels can be removed for inspection or to remove the filters from the unit

		M	L	XL
<b>INSTALLATION</b>				
<b>UNDER</b>	<b>Supply</b>			
	<b>Return</b>			
<b>OVER</b>	<b>Supply</b>	X	X	X
	<b>Return</b>			
<b>WEIGHT</b>		<b>M</b>	<b>L</b>	<b>XL</b>
PLENUM + FILTER ePM 1 50% + DAMPER [kg]		67,6	83,6	117,6

## OPTIONAL ACCESSORY: B97D - PLENUM + FILTER COARSE 60% A TASCA

## OPTIONAL ACCESSORY: B97E - PLENUM + FILTER COARSE 60% A TASCA + DAMPER

The plenum with soft pocket filters must be installed on the return side of the unit and provides better aeraulic efficiency than standard filters.

- It is possible to remove the front panels for inspection or to remove the filters from the unit.
- Available in version with Damper.

		M	L	XL
<b>INSTALLATION</b>				
<b>UNDER</b>	<b>Supply</b>			
	<b>Return</b>	X	X	X
<b>OVER</b>	<b>Supply</b>			
	<b>Return</b>			
<b>WEIGHT</b>		<b>M</b>	<b>L</b>	<b>XL</b>
PLENUM + FILTER COARSE 60% [kg]		59	71,6	97,6
PLENUM + FILTER COARSE 60% + DAMPER [kg]		67,6	83,6	117,6

## OPTIONAL ACCESSORY: B97F - PLENUM + FILTER COARSE 60%

## OPTIONAL ACCESSORY: B97G - PLENUM + FILTER COARSE 60% + 1 GRILLE

The plenum with filters is designed in combination with the OVER units with intake from the basement, to filter the aeraulic flow in entrance to the evaporating coil.

The accessory must be installed on the unit's intake and access to the filters must be guaranteed for routine maintenance operations

- It is possible to remove the front panels for inspection or to remove the filters from the unit

		M	L	XL
<b>INSTALLATION</b>				
<b>UNDER</b>	<b>Supply</b>			
	<b>Return</b>			
<b>OVER</b>	<b>Supply</b>			
	<b>Return</b>	X	X	X
<b>WEIGHT</b>		<b>M</b>	<b>L</b>	<b>XL</b>
PLENUM + FILTER COARSE 60% [kg]		59	72	98
PLENUM + FILTER COARSE 60% + 1 GRILLE [kg]		59	72	98

## OPTIONAL ACCESSORY: B97H - PLENUM FREE COOLING

The plenum must be installed on the air intake of the machine and allows, under certain thermo-hygrometric conditions, the room to be conditioned to be cooled directly with the air coming from outside, disposing of the thermal load without the contribution of the cooling circuit.

The damper has a double septum and the microprocessor system continuously regulates the quantity of external air to be introduced into the room to be conditioned according to the set-point. It is possible to remove the front panels for inspection or to remove the filters from the unit.

		M	L	XL
<b>INSTALLATION</b>				
<b>UNDER</b>	Supply			
	Return	X	X	X
<b>OVER</b>	Supply			
	Return			
<b>WEIGHT</b>		<b>M</b>	<b>L</b>	<b>XL</b>
PLENUM + DAMPER FC		[kg]	61,6	75,6
				107,6

### DAMPER AIR EXHAUST - Not provided

#### WARNING

**IT IS COMPULSORY TO INSTALL IN THE ROOM TO BE CONDITIONED A MOTORIZED DAMPER APPROPRIATELY DIMENSIONED FOR THE EXHAUSTION OF AIR FROM THE ROOM DURING FREE-COOLING OPERATION.**

During free-cooling operation, the air conditioner supplies ambient air directly into the room, this causes an increase in air pressure inside the room.

The exhaustion damper avoids the increase in pressure in the room.

The damper must be installed at the highest point of the room to exhaust excess hot air to the outside. Install the damper if possible, in opposite position to air conditioner.

The damper is controlled by the modulating signal 0-10Vdc of the free-cooling control of the air conditioner. The 24Vac power supply of the servomotor and the 0-10Vdc free-cooling signal is available on the unit's electrical terminal block (see wiring diagram for connections). Air exhaustion must be protected with a rain cover and a grille (at Customer care). The electrical connection cables are not supplied.

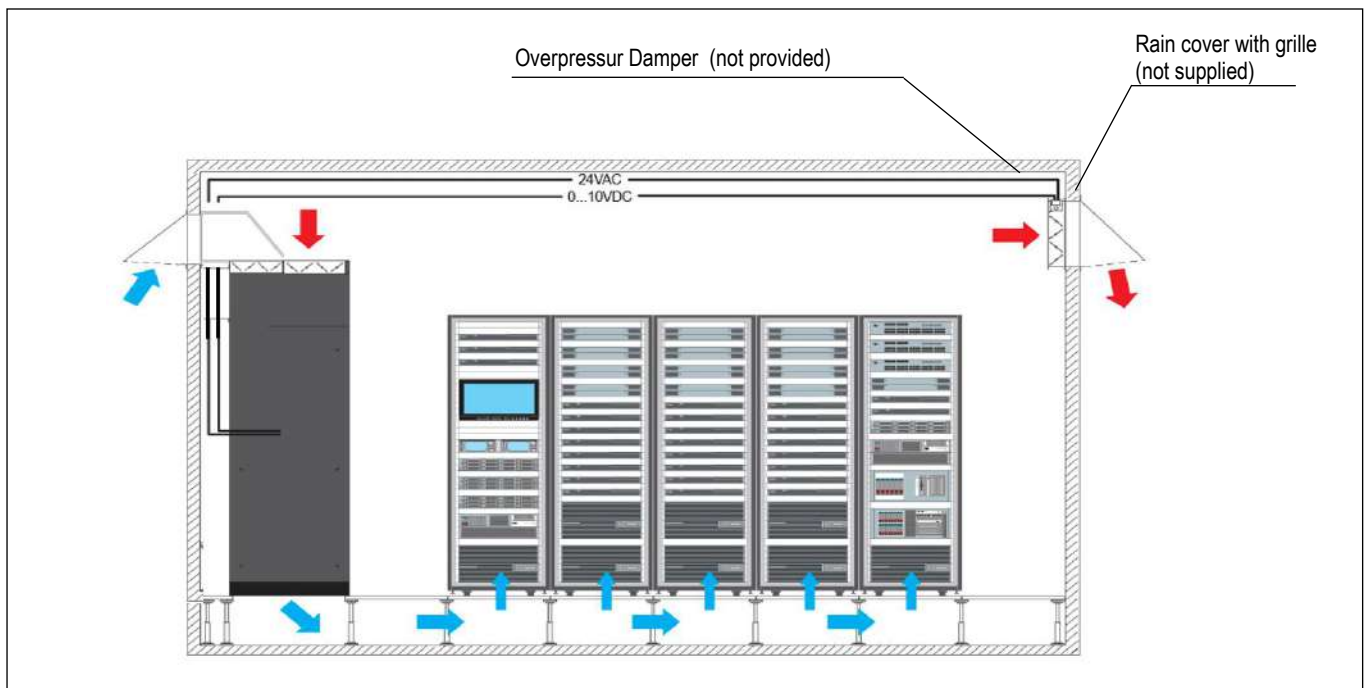

## OPTIONAL ACCESSORIES: A531 - DAMPER ON-OFF

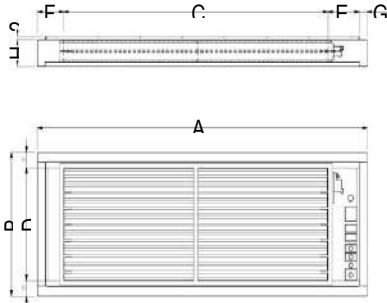

Motorised ON/OFF non-return air damper positioned above the unit in both UNDER and OVER versions.

The Damper opens when the fans start up to allow the correct flow of air into the unit during operation. When the unit has an alarm or when it is set to OFF, the Damper closes excluding the unit from air circulation.

In the UNDER version the Damper is equipped with levers that allow it to be lifted without the use of tools, to guarantee easy and safe removal of the air filters from the front during normal maintenance operations.

The accessory can be supplied together with the plenum and support frame, for details please refer to the dedicated chapter.

The accessory mandatorily requires the presence of accessory "9973 Packaging with wooden cage".

### STRUCTURE

- Sheet steel frame with protective surface treatment according to UNI ISO 9227/ASTMB117 and ISO 7253, and painted with epoxy powders. Colour RAL 9005;
- Damper with opposed fins made of sheet steel;
- Servo motor for damper control;
- Terminal box for electrical connection to the unit.

DAMPER ON/OFF		M	L	XL
N° DAMPERS	[-]	1	1	2
Height *	[mm]	80	80	80
Length Damper *	[mm]	969	1423	1133
Depth Damper *	[mm]	750	750	750
WEIGHT Damper *	[kg]	8,6	12	10

\* Data referred to single Damper

## OPTIONAL ACCESSORIES: B981 - SUPPORTING FRAME H 350 – 500 mm OPTIONAL ACCESSORIES: B982 - SUPPORTING FRAME H 500 - 750 mm OPTIONAL ACCESSORIES: B983 - SUPPORTING FRAME H 750 - 1000 mm

The accessory is supplied as an assembly kit and includes the unit's support frame and its attachment to the machine base (internal fixing).

The new design allows for easy installation and quick height adjustment. The footprint is completely integrated into the machine's floor plan. It is not possible to install the support frame together with the plenums underneath the machine.

The frame is available in 3 different heights for installation flexibility.

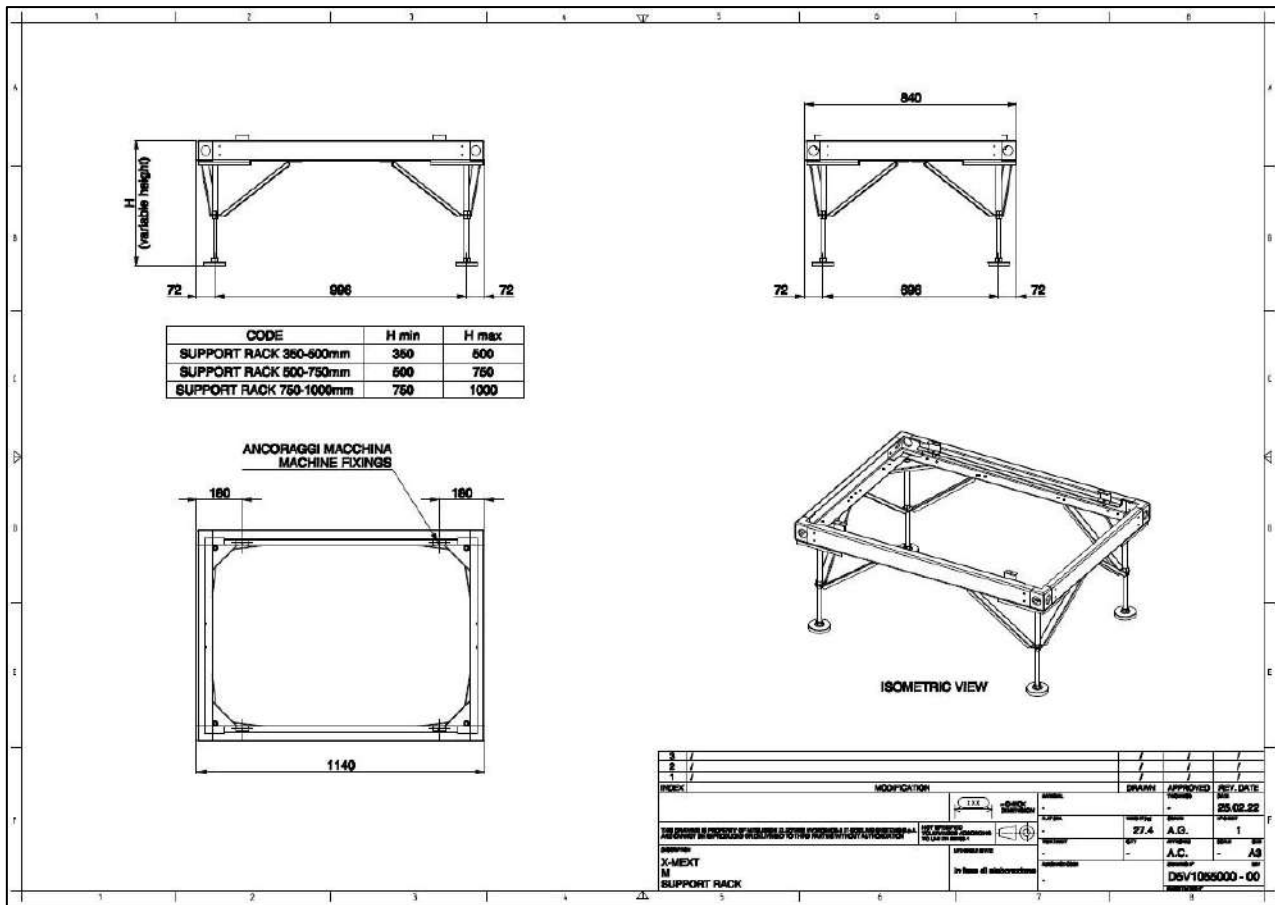

B982 - H max 750		M	L	XL
Min Height	mm	500	500	500
Max Height	mm	750	750	750
WEIGHT	[kg]	27,7	44,8	53,8

B981 - H max 500		M	L	XL
Min Height	mm	350	350	350
Max Height	mm	500	500	500
WEIGHT	[kg]	27,4	44,5	53,5

B983 - H max 1000		M	L	XL
Min Height	mm	750	750	750
Max Height	mm	1000	1000	1000
WEIGHT	[kg]	28	45,1	54,1

## OPTIONAL ACCESSORIES: B991 – INSULATION

The accessory is designed to acoustically insulate the air-conditioning unit's panels. The sound pressure reduction of the unit is approximately 2dB(A). The reduction refers only to the radiated sound level values or the front of the unit (blind front panels).

The noise data on the intake and supply ports are not reduced.

The rear, side and front panels (not GRILLEti) consist of:

- External part with painted sheet metal panel
- Sound-absorbing insulation
- Inner part in hot-dip galvanised sheet steel
- The insulation provides fire protection comparable to Class 0 according to EN 13501-1.

The accessory, when combined with the OVER units, obligatorily requires that the air return is carried out from the basement of the unit and the presence of the blind front panel.

The accessory increases the weight of the unit.

FRAME		WEIGHT		
		M	L	XL
UNDER/OVER	kg	36	44	144

# DRILLING OF RAISED FLOOR FOR UNDER MACHINES

x-AV3 DW / DW DF / DW FC

Data Book  
DB\_CV\_x-AV3-i-G02-DW\_102022\_EN\_rev00

## DRILLING OF RAISED FLOOR WITHOUT SUPPORT FRAME

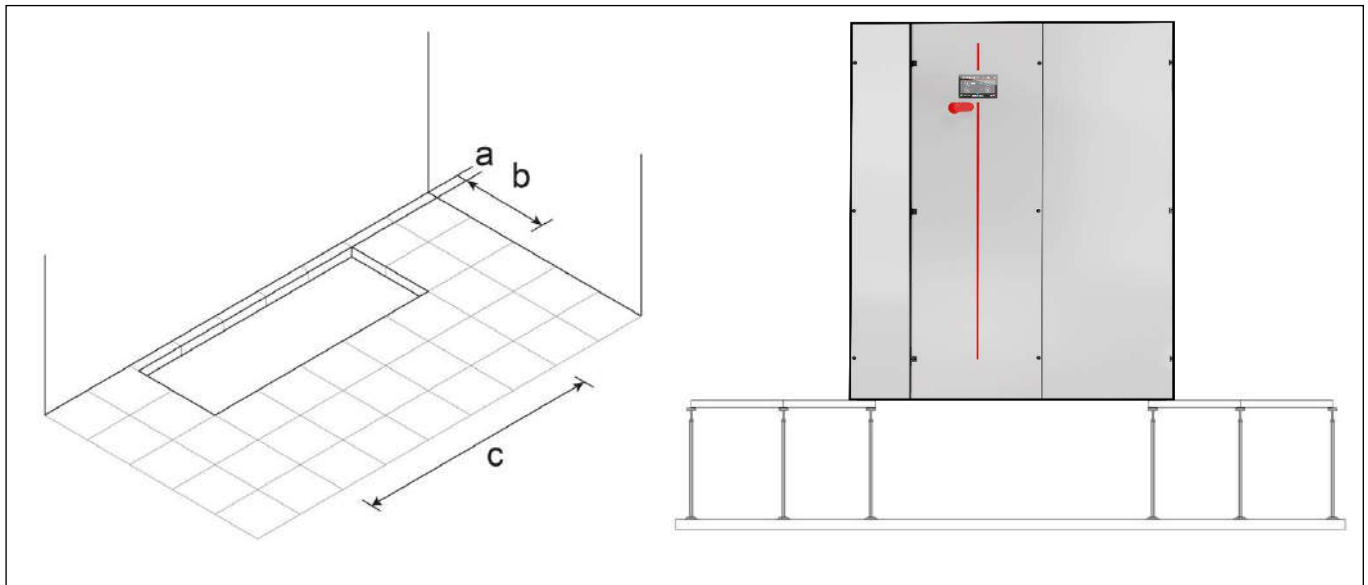

Provide a hole of the size shown in the table

FRAME		M	L	XL
a	mm	60	60	60
b	mm	765	765	765
c	mm	1082	1870	2820

## DRILLING OF RAISED FLOOR WITH SUPPORT FRAME

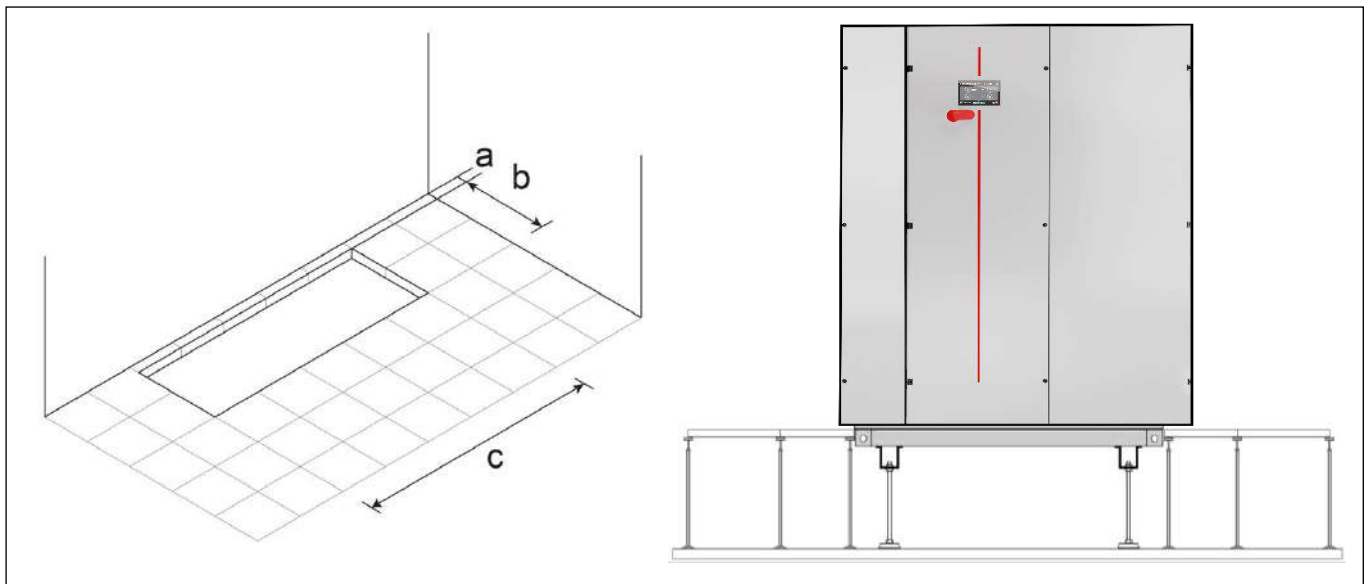

Provide a hole of the size shown in the table

FRAME		M	L	XL
a	mm	25	25	25
b	mm	840	840	840
c	mm	1142	1930	2880

**M UNDER**  
Dimensioni in mm

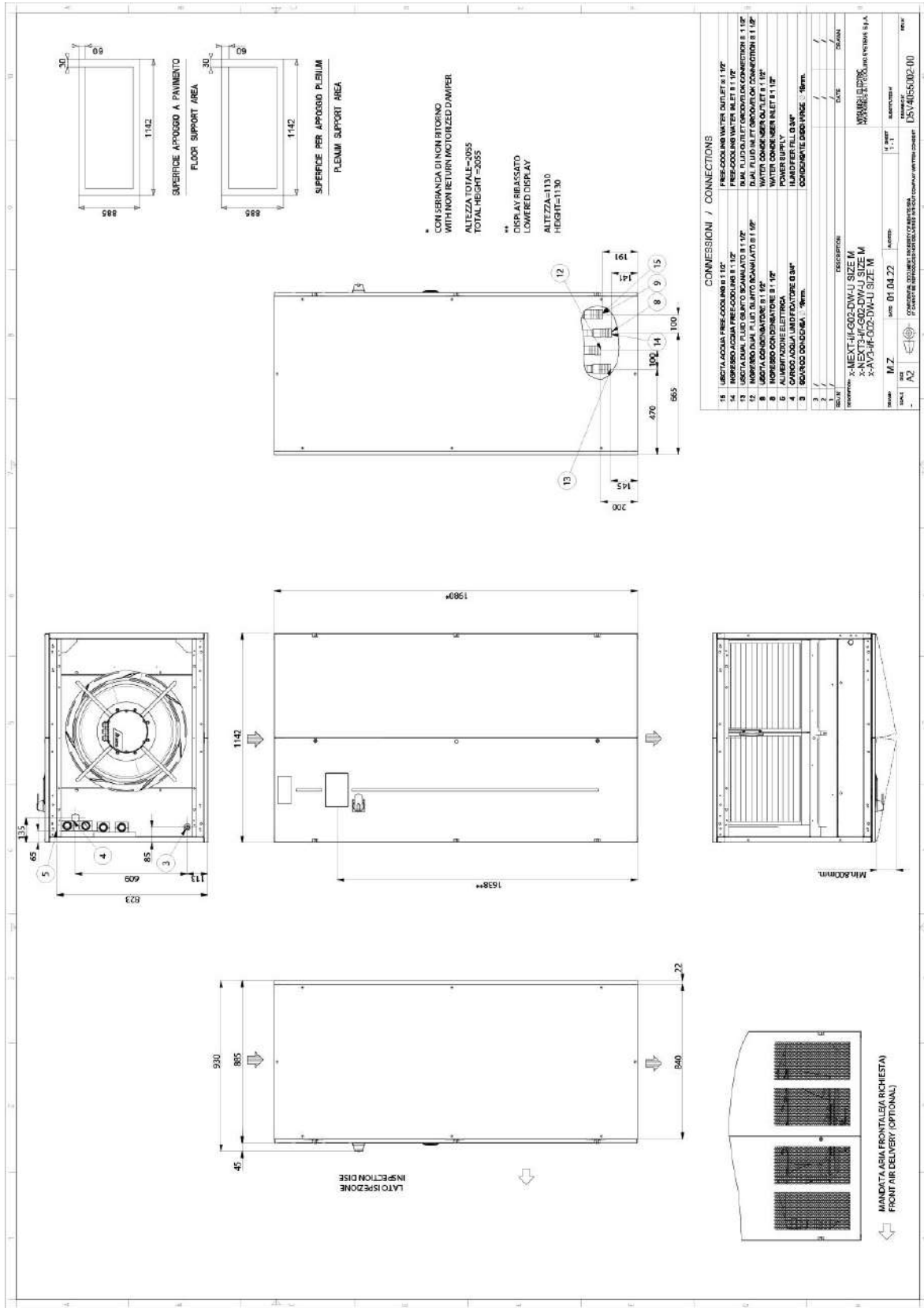

M OVER  
Dimensioni in mm

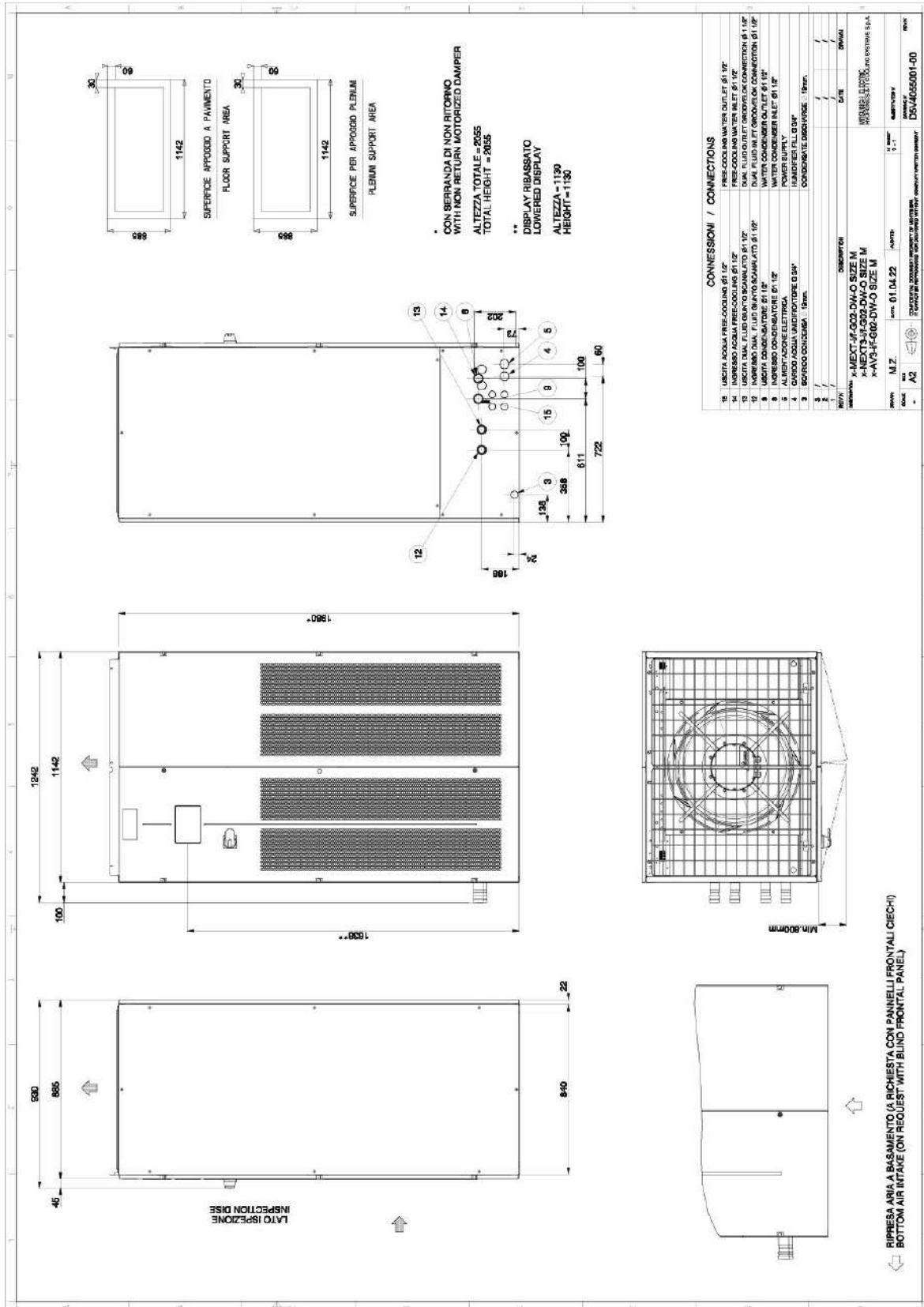



L UNDER  
Dimensioni in mm

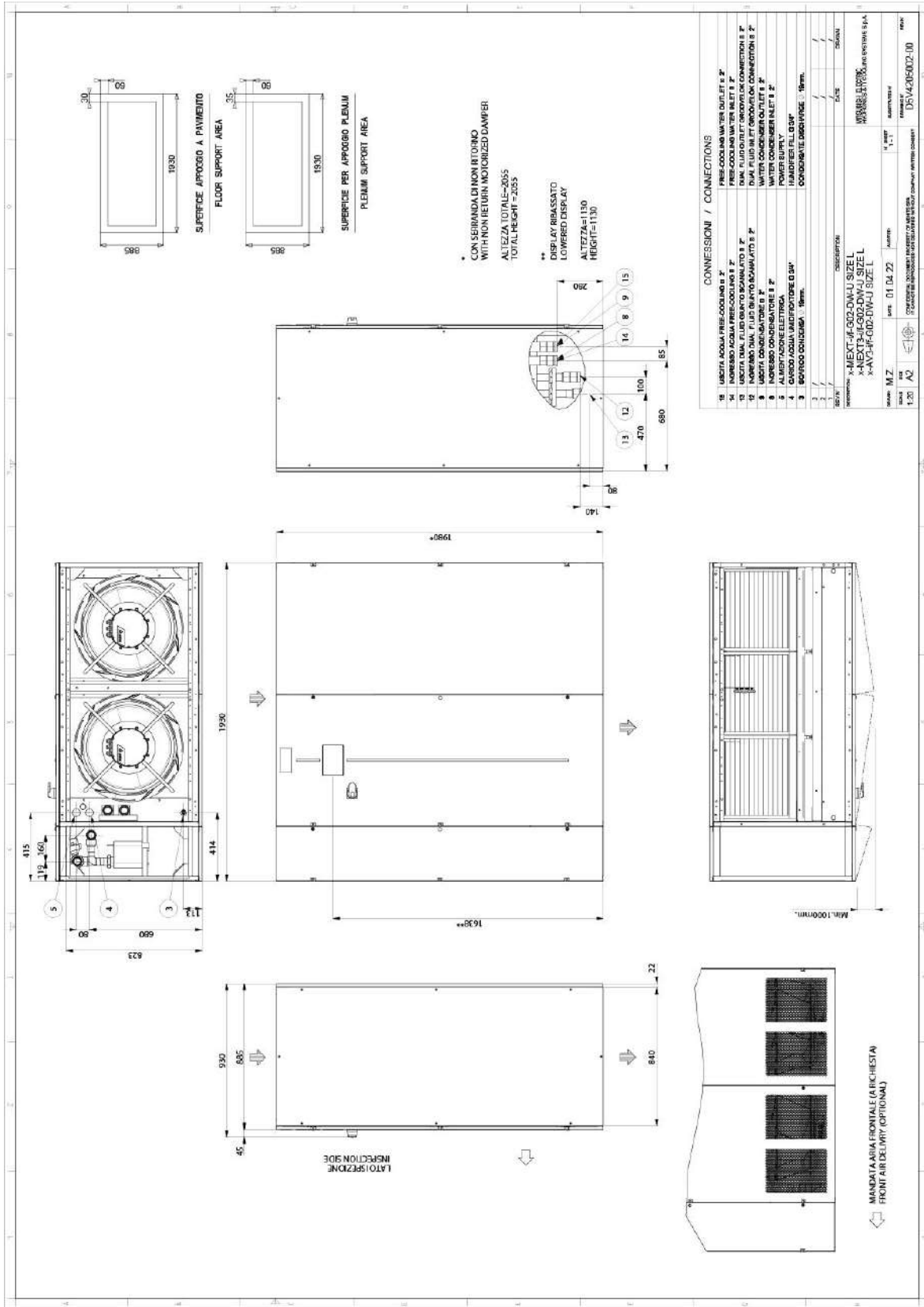

L OVER  
Dimensioni in mm

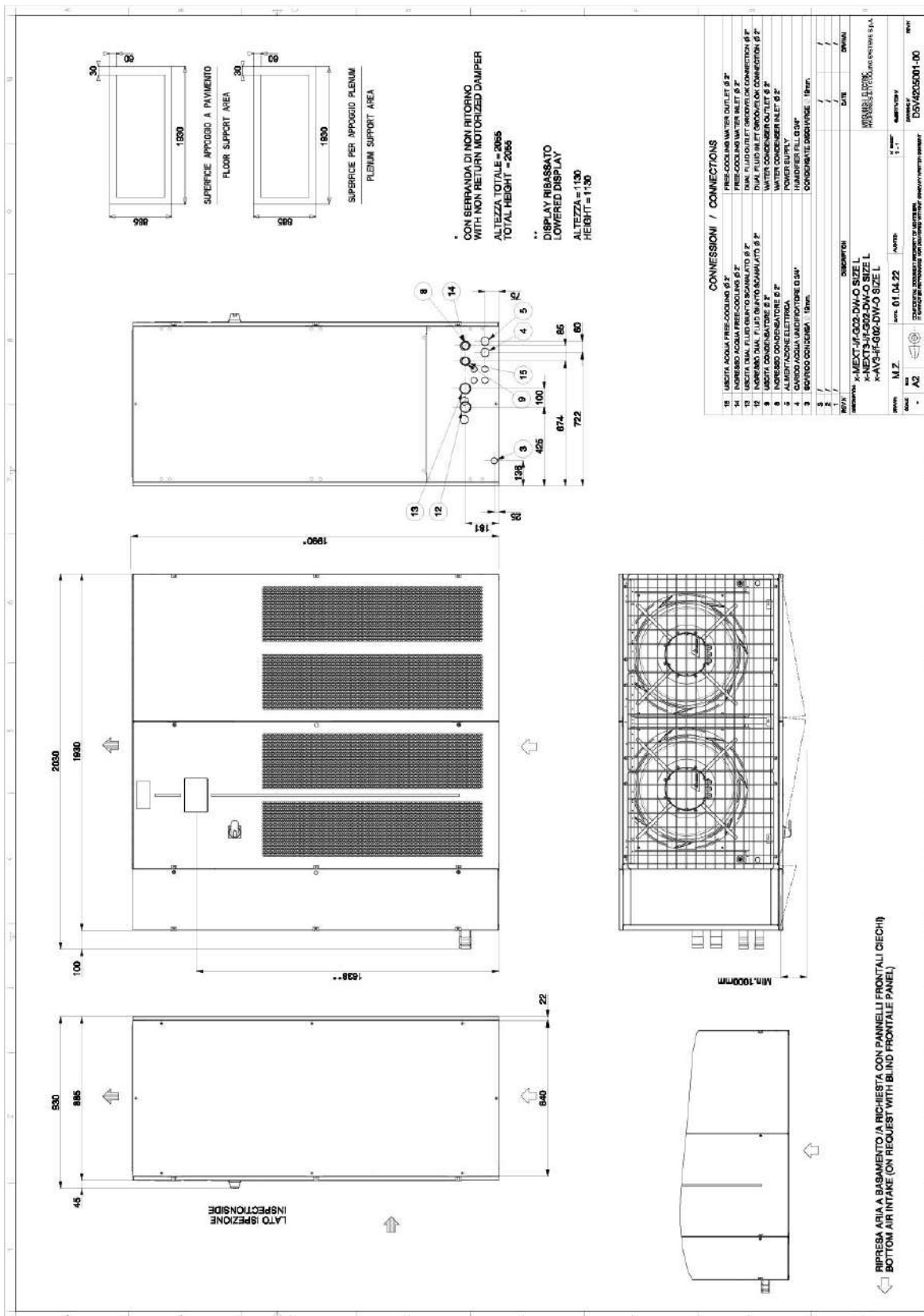

**XL UNDER**  
Dimensioni in mm

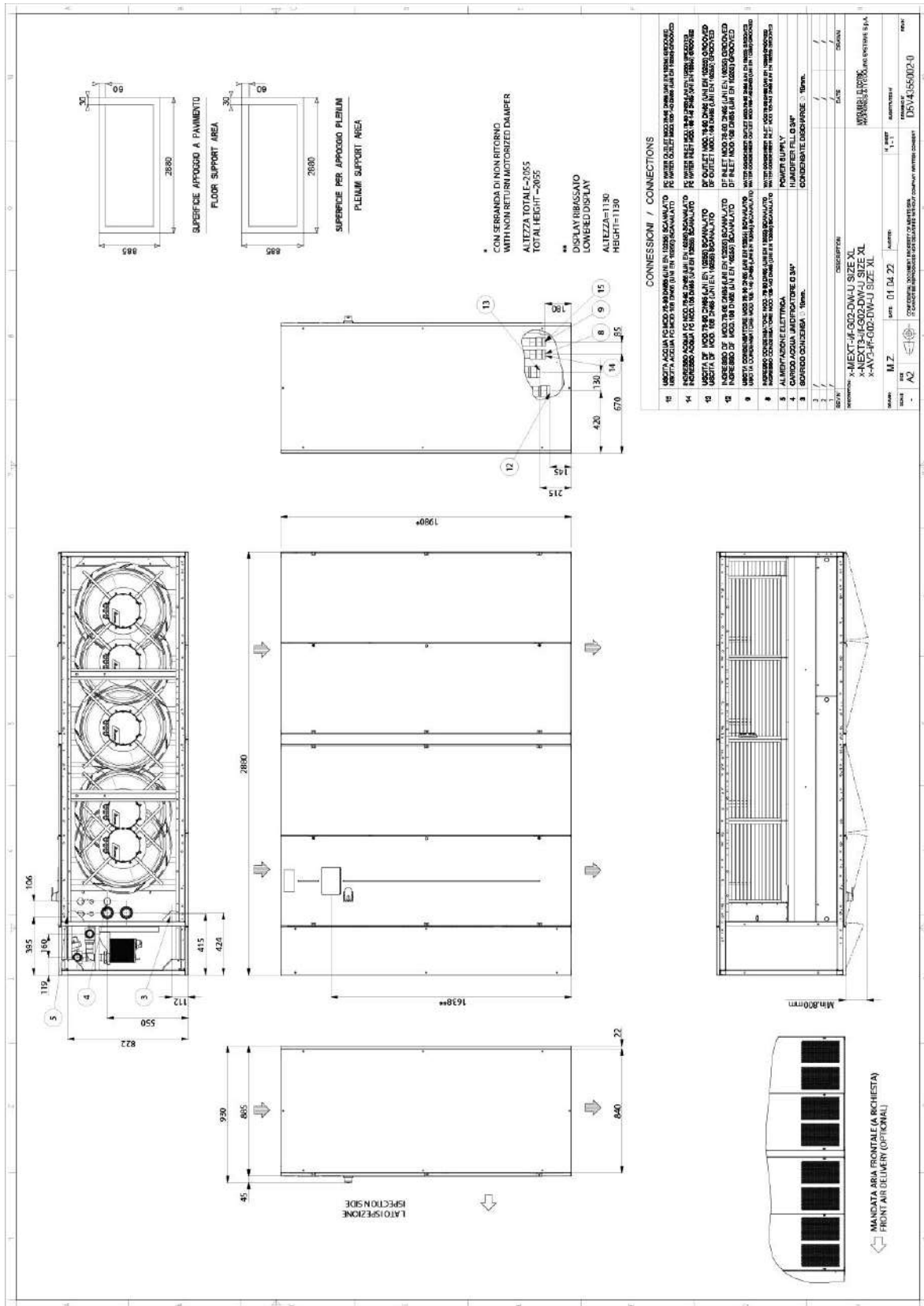

**XL OVER**  
Dimensioni in mm

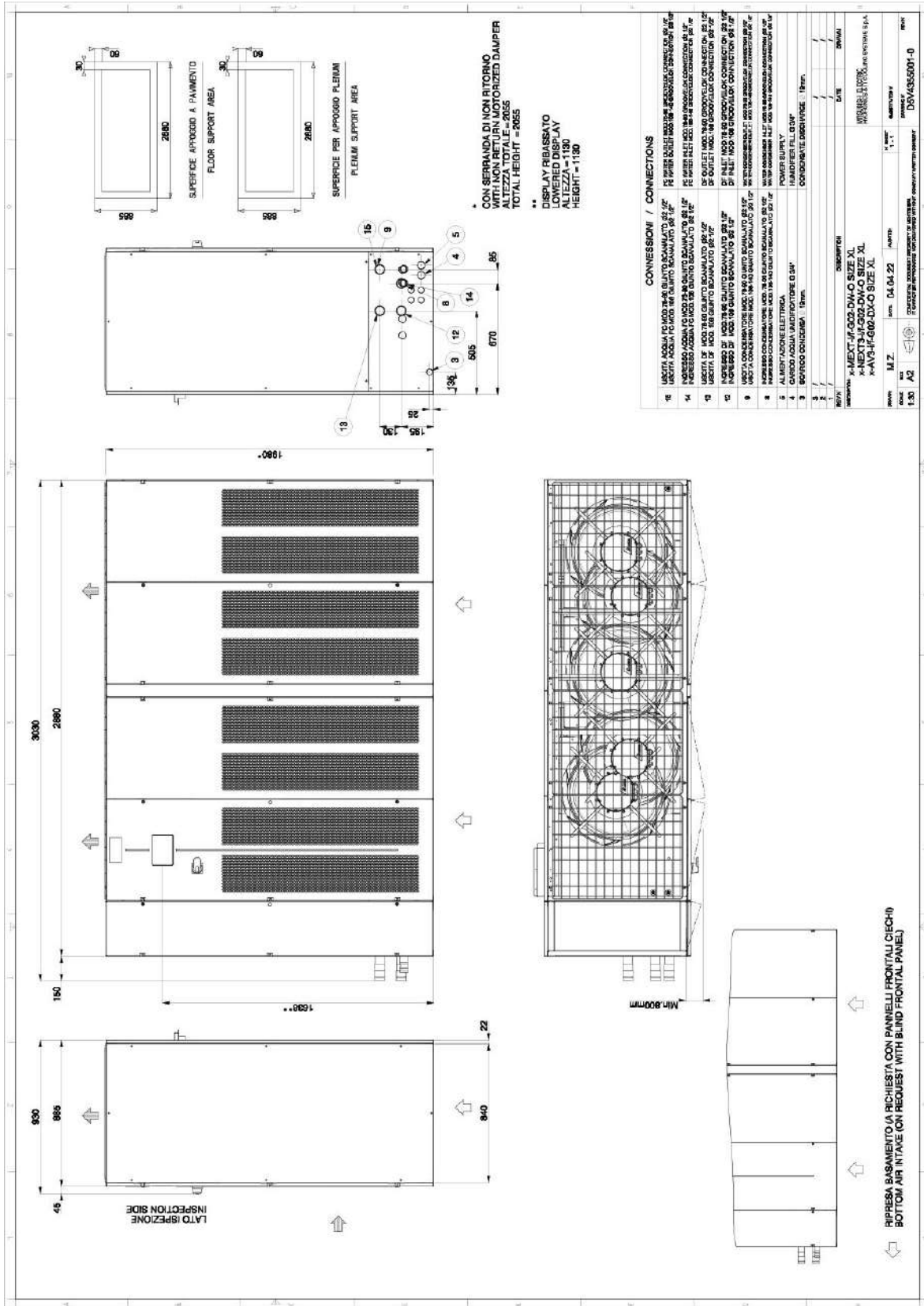

## UNDER MACHINE WITH DUCT ON AIR INTAKE

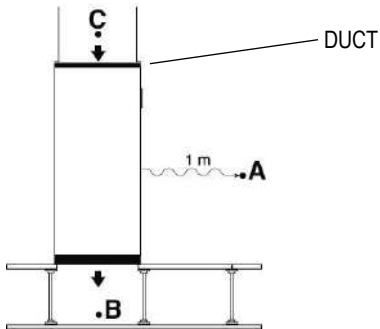

Lp A = Front side Under catalogue value

Lp B = Air delivery Under catalogue value

Lp C = Air intake Under catalogue value

The points B and C do not influence the point A

## UNDER MACHINE WITH PLENUM ON AIR

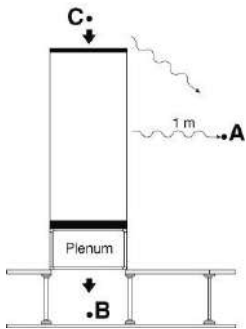

Lp A = Front side Under catalogue value

Lp B = Air delivery Under catalogue value –plenum noise reduction

Lp C = Air intake Under catalogue value

$$Lp A+C = 10 \log_{10} \left( 10^{\frac{LpA}{10}} + 10^{\frac{LpC}{10}} \right)$$

The points B and C do not influence the point A

## UNDER MACHINE WITH PLENUM ON AIR INTAKE

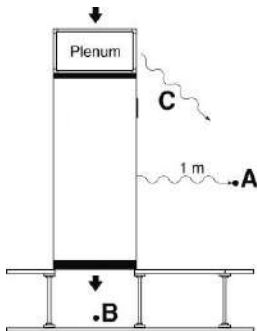

Lp A = Front side Under catalogue value

Lp B = Air delivery Under catalogue value –plenum noise reduction

Lp C = Air intake Under catalogue value

$$Lp A+C = 10 \log_{10} \left( 10^{\frac{LpA}{10}} + 10^{\frac{LpC}{10}} \right)$$

The points B and C do not influence the point A

## OVER MACHINE WITH DUCT

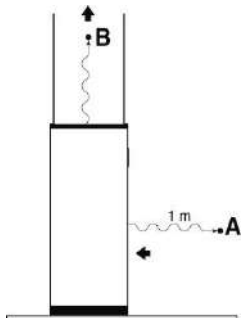

Lp A = Air intake Over catalogue value

Lp B = Air delivery Over catalogue value

The points B and C do not influence the point A



## OVER MACHINE WITH PLENUM ON AIR DELIVERY

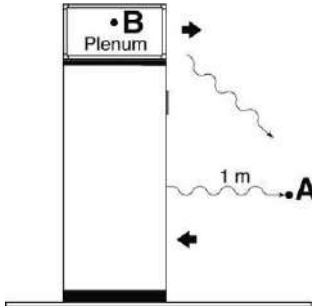

Lp A = Air intake Over catalogue value

Lp B = Air delivery Over catalogue value – plenum noise reduction

$$Lp A+B = 10 \log_{10} \left( 10^{\frac{LpA}{10}} + 10^{\frac{LpC}{10}} \right)$$

## OVER MACHINE WITH DUCT AND PLENUM ON AIR DELIVERY

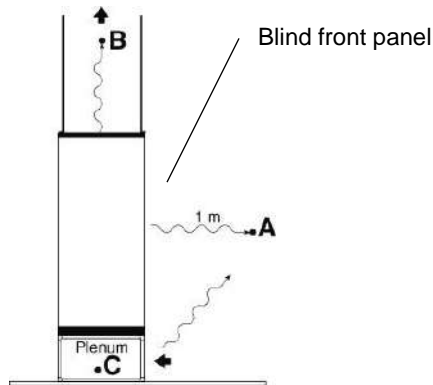

Lp A = Front side Over catalogue value

Lp B = Air delivery Over catalogue value

Lp C = Lp A + 6dB(A) - plenum noise reduction

$$Lp A+C = 10 \log_{10} \left( 10^{\frac{LpA}{10}} + 10^{\frac{LpC}{10}} \right)$$

The point B do not influence the point A+C

## OVER MACHINE WITH DUCT AND PLENUM ON AIR DELIVERY

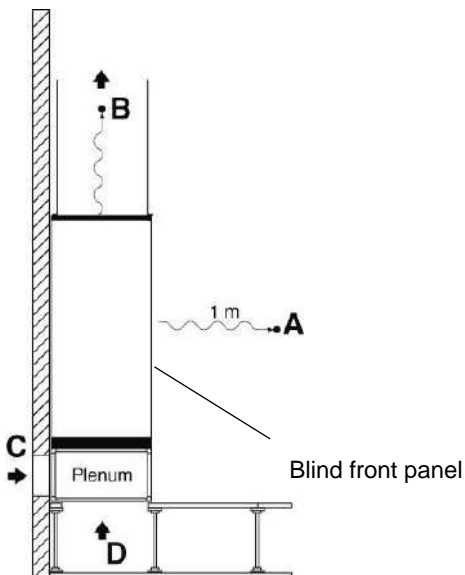

Lp A = Front side Over catalogue value

Lp B = Air delivery Over catalogue value

Lp C = Lp D = Lp A + 6 dB(A) - plenum noise reduction

The points B, C and D do not influence the point A

### IMPORTANT

The declared noise levels are intended in free field conditions.

The noise pressure level of an installed unit is affected by the room acoustic characteristics.

Please consider an average noise increase of +4/+6 dB(A).

## VALVE PRESSURE DROP CALCULATION AS FUNCTION OF WATER FLOW RATE

x-AV3 DW / DW DF / DW FC

Data Book

DB\_CV\_x-AV3-i-G02-DW\_102022\_EN\_rev00

Flow coefficient kv defines the water flow (between 5°C and 40°C) expressed in m<sup>3</sup>/h that cross a valve with a pressure drop of 1bar (100kPa).

With this data is possible to calculate the localized pressure drop as function of the water flow rate.

$$dP = (Q / kv)^2$$

dP (bar) = localized pressure drop of valve;

Q (m<sup>3</sup>/h) = water flow rate – it varies according to the desired operating condition;

kv (m<sup>3</sup>/h) = valve flow coefficient.

The formula allows to calculate the value of the localized pressure drop (in bar).

The pressure drops values showed on the documentation are supplied in kPa.

Is possible to change from one unit to another through the following conversion.

1 bar = 100kPa

# AIR FILTERS REPLACEMENT FOR UNDER VERSION MACHINES SIZE M - L - XL

x-AV3 DX / DX DF

Data Book

T\_x-AV3-i-DX-DXDF\_0822\_IT - HFC R410A

Thanks to the new design of the unit, it is possible to extract the air filters for routine maintenance operations from the front of the machine, both in installations with free unit intake and when there is a plenum, ducting or damper.

The air filters are foldable and allow easy extraction. When a return plenum is present, the front panel of the plenum must be removed using the screws provided to access the air filters.

When a damper is present, there is a lifting system that locks the damper in the open position, guaranteeing access to the filtering section.

When ducting is present, access to the filtering section must be provided by means of a removable door.

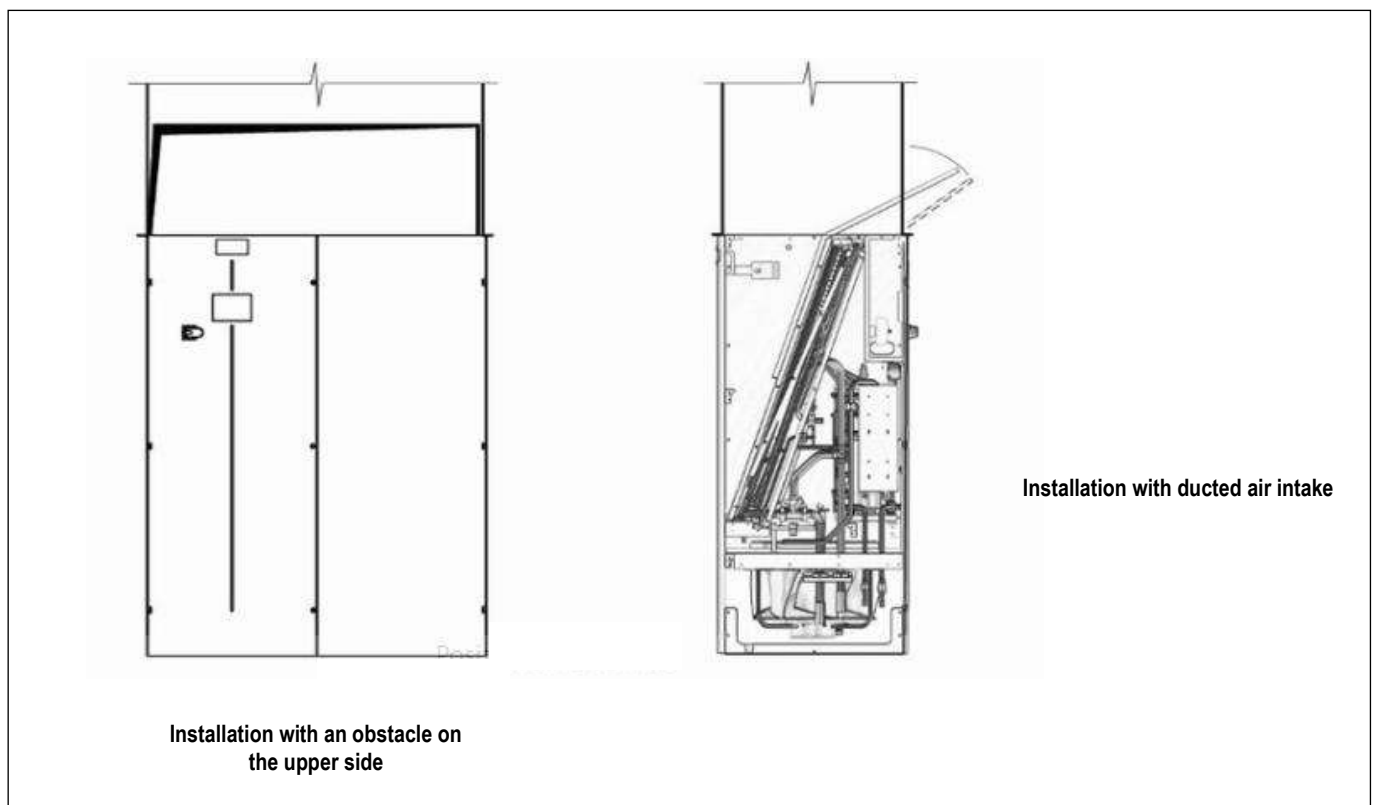
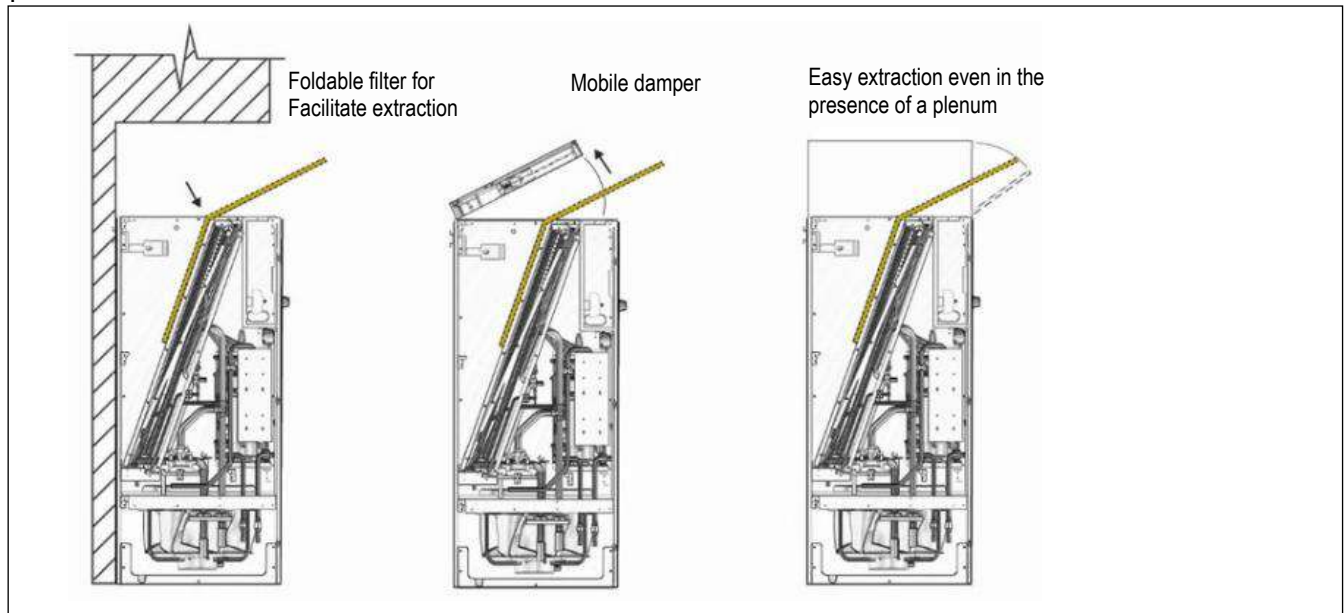



## SHIPMENT: PACKAGING DIMENSIONS

Values referred to basic machine. The presence of some accessories increases the weight of machine.  
The machines are shipped on pallet and covered with shrink wrap.  
On request packing on pallet covered with shrink wrap and wooden cage.

**STANDARD PACKING DIMENSIONS:**  
Pallet + Nylon

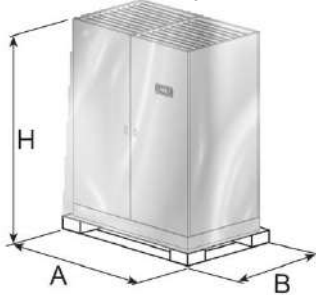

FRAME	A (mm)	B (mm)	H (mm)
M	1410	1115	2185
L	2170	1115	2185
XL	3130	1115	2185

**OPTIONAL 9969: Pallet + Wooden cage + Nylon**

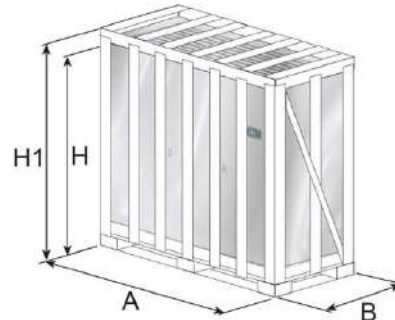

FRAME	A (mm)	B (mm)	H (mm)	H1 (*) (mm)
M	1410	1115	2275	2425
L	2170	1115	2275	2425
XL	3130	1115	2275	2425

H1 (\*) = Packaging height with Damper installed on unit

## SHIPMENT WEIGHT

### STANDARD PACKING - VERSION DW

Model	29	40	51	52	67	76	78	90	108	140	
Frame	M	M	M	L	L	L	XL	XL	XL	XL	
WEIGHT UNDER	kg	412	418	419	541	582	583	1031	1032	1156	1158
WEIGHT OVER	kg	403	409	410	522	563	564	991	992	1116	1118

### ACCESSORIO 9969: WOODEN CAGE PACKING - VERSION DW

Modello	29	40	51	52	67	76	78	90	108	140	
Grandezza	M	M	M	L	L	L	XL	XL	XL	XL	
Peso UNDER	kg	457	463	464	602	643	644	1111	1112	1236	1238
Peso UNDER (1)	kg	462	468	469	608	649	650	1120	1121	1245	1247
Peso OVER	kg	448	454	454	584	624	625	1071	1072	1196	1198
Peso OVER (1)	kg	453	459	459	590	630	631	1080	1081	1205	1207

(1) Machine with accessory A531 Damper on/off - WEIGHT Damper to add up

### STANDARD PACKING - VERSION DW DF / DW FC

Modello	29	40	51	52	67	76	78	90	108	
Grandezza	M	M	M	L	L	L	XL	XL	XL	
Peso UNDER	kg	468	474	474	712	752	753	1088	1089	1213
Peso OVER	kg	458	464	465	693	733	734	1047	1049	1172

# SHIPMENT

x-AV3 DW / DW DF / DW FC

Data Book

DB\_CV\_x-AV3-i-G02-DW\_102022\_EN\_rev00

## OPTIONAL ACCESSORY 9969: WOODEN CAGE PACKING — VERSION DW DF

Modello		29	40	51	52	67	76	78	90	108
Grandezza		M	M	M	L	L	L	XL	XL	XL
Peso UNDER	kg	513	519	520	773	813	814	1168	1169	1293
Peso UNDER (1)	kg	518	524	525	779	819	820	1177	1178	1301
Peso OVER	kg	503	509	510	754	794	795	1127	1128	1251
Peso OVER (1)	kg	508	514	515	760	800	801	1136	1137	1260

(1) Machine with accessory A531 Damper on/off - WEIGHT Damper to add up

## ACCESSORIES: PACKING DIMENSIONS AND SHIPMENT WEIGHT

Dimensions/weights pallet		M	L	XL
WEIGHT pallet (to add at WEIGHT accessory)	[kg]	25	38	55
Lenght	[mm]	1410	2170	3130
Width	[mm]	1115	1115	1115
Plenum				
Packing type	[-]	Pallet + film termoretraibile		
Height	[mm]	660	660	660
Support frame				
Packing type	[-]	Pallet + film termoretraibile		
Height	[mm]	400	400	400

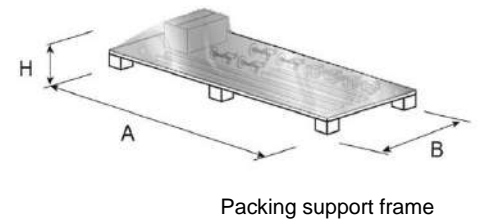
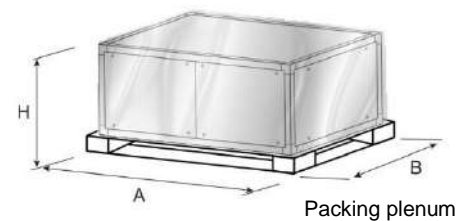

Kit dual power supply		M	L	XL
Packing type	[-]	Cardboard box		Cardboard plastic
WEIGHT packing	[kg]	5	5	12
Lenght	[mm]	500	500	600
Width	[mm]	400	400	450
Height	[mm]	210	210	228,5

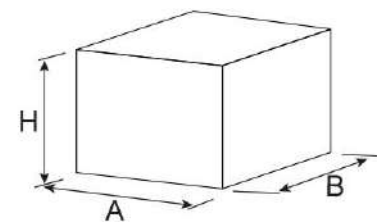

Packing kit dual power supply

## KIT DUAL POWER SUPPLY FOR SIZES M / L

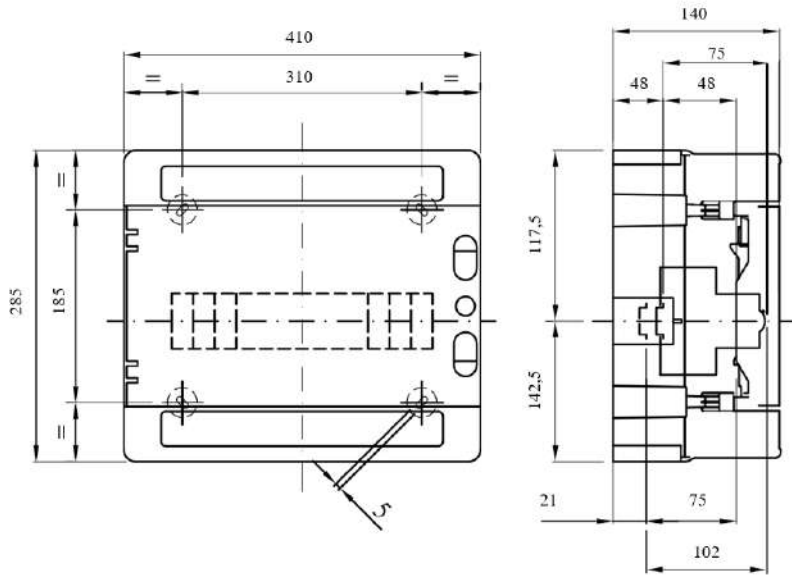

## KIT DUAL POWER SUPPLY FOR SIZE XL

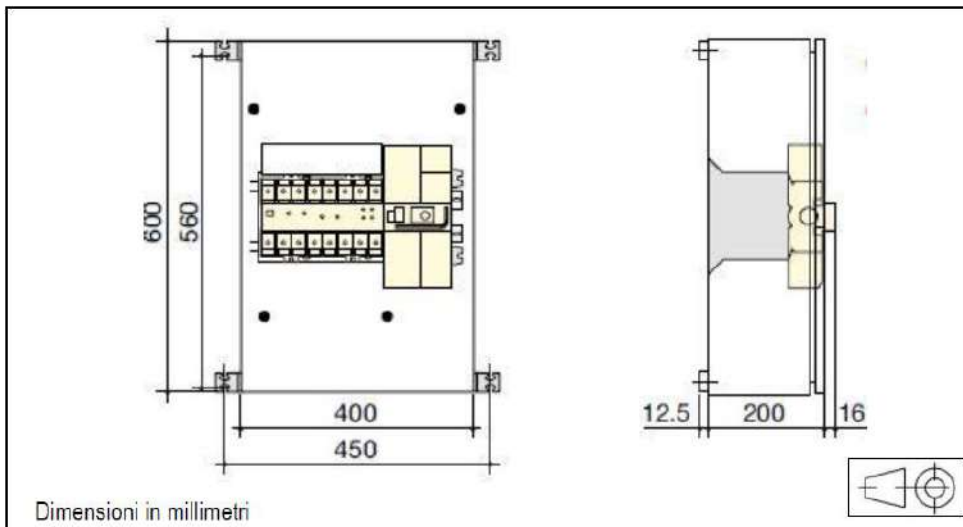

---

**MITSUBISHI ELECTRIC  
HYDRONICS & IT COOLING SYSTEMS S.p.A.**

**Head Office:**

Via Caduti di Cefalonia 1 - 36061 Bassano del Grappa (VI) - Italy

Tel (+39) 0424 509 500 - Fax (+39) 0424 509 509

[www.melcohit.com](http://www.melcohit.com)